



## OPTIBAR P 2010 Handbook

Hygienic pressure transmitter with flush welded diaphragm

All rights reserved. It is prohibited to reproduce this documentation, or any part thereof, without the prior written authorisation of KROHNE Messtechnik GmbH.

Subject to change without notice.

Copyright 2020 by  
KROHNE Messtechnik GmbH - Ludwig-Krohne-Str. 5 - 47058 Duisburg (Germany)

<b>1</b>	<b>Safety instructions</b>	<b>5</b>
1.1	Intended use .....	5
1.2	Technical limits .....	5
1.3	Certification .....	5
1.4	Safety instructions from the manufacturer .....	6
1.4.1	Copyright and data protection .....	6
1.4.2	Disclaimer .....	6
1.4.3	Product liability and warranty .....	7
1.4.4	Information concerning the documentation .....	7
1.4.5	Warnings and symbols used .....	8
1.5	Safety instructions for the operator .....	8
<b>2</b>	<b>Device description</b>	<b>9</b>
2.1	Scope of delivery .....	9
2.2	Nameplate .....	10
<b>3</b>	<b>Installation</b>	<b>11</b>
3.1	General notes on installation .....	11
3.2	Installation specifications .....	11
3.3	Mounting .....	12
3.3.1	Installation steps for connections acc. to DIN 3852 .....	13
3.3.2	Installation steps for connections acc. to EN 837 .....	13
3.3.3	Installation steps for NPT connections .....	13
3.3.4	Installation steps for clamp and Varivent connections .....	14
3.3.5	Installation steps for flange connections .....	14
<b>4</b>	<b>Electrical connections</b>	<b>15</b>
4.1	Safety instructions .....	15
4.2	Terminal assignment .....	15
4.3	Electrical connection diagram .....	16
<b>5</b>	<b>Service</b>	<b>17</b>
5.1	Maintenance .....	17
5.2	Recalibration .....	17
5.3	Spare parts availability .....	17
5.4	Availability of services .....	17
5.5	Repairs .....	17
5.6	Returning the device to the manufacturer .....	18
5.6.1	General information .....	18
5.6.2	Form (for copying) to accompany a returned device .....	19
5.7	Disposal .....	19

6 Technical data	20
6.1 Technical data.....	20
6.2 Dimensions and weights .....	23
6.3 Measuring ranges.....	26
7 Notes	27

## 1.1 Intended use

**CAUTION!**

*Responsibility for the use of the measuring devices with regard to suitability, intended use and corrosion resistance of the used materials against the measured fluid lies solely with the operator.*

**INFORMATION!**

*The manufacturer is not liable for any damage resulting from improper use or use for other than the intended purpose.*

The **OPTIBAR P 2010** pressure transmitter is designed to measure the absolute pressure and gauge pressure of gases and liquids.

## 1.2 Technical limits

The device was constructed solely for use within the technical limits indicated on the nameplate and in the technical data. Applications outside of these limits are not permitted and could lead to significant risk of accident. For this reason, observe the following limits:

- Do not exceed the maximum working pressure (MWP).
- Do not exceed the indicated permissible operating temperature range.
- The permissible ambient temperatures given may not be exceeded or undershot.
- Check the materials used for the wetted parts (e.g. gasket, process connection, separating diaphragm etc.) for suitability as regards process compatibility.

## 1.3 Certification

### CE marking

The device fulfils the statutory requirements of the following EU directives:

- EMC Directive 2014/30/EU
- EMC specification acc. to EN 61326-1:2013
- RoHS Directive 2011/65/EU

The manufacturer certifies successful testing of the product by applying the CE marking.

### Pressure equipment directive (PED)

Devices with a permissible pressure  $PS \leq 200$  bar (20 MPa) comply with Pressure equipment directive (PED) 2014/68/EU Article 4 Section (3) and are not subject to a conformity assessment. These devices were designed and manufactured in accordance with sound engineering practice (SEP).

The CE marking on the device does not apply to the Pressure Equipment Directive.

**DANGER!**

*For devices used in hazardous areas, additional safety notes apply; please refer to the Ex documentation.*

## 1.4 Safety instructions from the manufacturer

### 1.4.1 Copyright and data protection

The contents of this document have been created with great care. Nevertheless, we provide no guarantee that the contents are correct, complete or up-to-date.

The contents and works in this document are subject to copyright. Contributions from third parties are identified as such. Reproduction, processing, dissemination and any type of use beyond what is permitted under copyright requires written authorisation from the respective author and/or the manufacturer.

The manufacturer tries always to observe the copyrights of others, and to draw on works created in-house or works in the public domain.

The collection of personal data (such as names, street addresses or e-mail addresses) in the manufacturer's documents is always on a voluntary basis whenever possible. Whenever feasible, it is always possible to make use of the offerings and services without providing any personal data.

We draw your attention to the fact that data transmission over the Internet (e.g. when communicating by e-mail) may involve gaps in security. It is not possible to protect such data completely against access by third parties.

We hereby expressly prohibit the use of the contact data published as part of our duty to publish an imprint for the purpose of sending us any advertising or informational materials that we have not expressly requested.

### 1.4.2 Disclaimer

The manufacturer will not be liable for any damage of any kind by using its product, including, but not limited to direct, indirect or incidental and consequential damages.

This disclaimer does not apply in case the manufacturer has acted on purpose or with gross negligence. In the event any applicable law does not allow such limitations on implied warranties or the exclusion of limitation of certain damages, you may, if such law applies to you, not be subject to some or all of the above disclaimer, exclusions or limitations.

Any product purchased from the manufacturer is warranted in accordance with the relevant product documentation and our Terms and Conditions of Sale.

The manufacturer reserves the right to alter the content of its documents, including this disclaimer in any way, at any time, for any reason, without prior notification, and will not be liable in any way for possible consequences of such changes.

### 1.4.3 Product liability and warranty

The operator shall bear responsibility for the suitability of the device for the specific purpose. The manufacturer accepts no liability for the consequences of misuse by the operator. Improper installation or operation of the devices (systems) will cause the warranty to be void. The respective "Standard Terms and Conditions" which form the basis for the sales contract shall also apply.

### 1.4.4 Information concerning the documentation

To prevent any injury to the user or damage to the device it is essential that you read the information in this document and observe applicable national standards, safety requirements and accident prevention regulations.

If this document is not in your native language and if you have any problems understanding the text, we advise you to contact your local office for assistance. The manufacturer can not accept responsibility for any damage or injury caused by misunderstanding of the information in this document.

This document is provided to help you establish operating conditions, which will permit safe and efficient use of this device. Special considerations and precautions are also described in the document, which appear in the form of icons as shown below.

### 1.4.5 Warnings and symbols used

Safety warnings are indicated by the following symbols.



**DANGER!**

*This warning refers to the immediate danger when working with electricity.*



**DANGER!**

*This warning refers to the immediate danger of burns caused by heat or hot surfaces.*



**DANGER!**

*This warning refers to the immediate danger when using this device in a hazardous atmosphere.*



**DANGER!**

*These warnings must be observed without fail. Even partial disregard of this warning can lead to serious health problems and even death. There is also the risk of seriously damaging the device or parts of the operator's plant.*



**WARNING!**

*Disregarding this safety warning, even if only in part, poses the risk of serious health problems. There is also the risk of damaging the device or parts of the operator's plant.*



**CAUTION!**

*Disregarding these instructions can result in damage to the device or to parts of the operator's plant.*



**INFORMATION!**

*These instructions contain important information for the handling of the device.*



**LEGAL NOTICE!**

*This note contains information on statutory directives and standards.*



• **HANDLING**

This symbol designates all instructions for actions to be carried out by the operator in the specified sequence.

➔ **RESULT**

This symbol refers to all important consequences of the previous actions.

## 1.5 Safety instructions for the operator



**WARNING!**

*In general, devices from the manufacturer may only be installed, commissioned, operated and maintained by properly trained and authorized personnel.  
This document is provided to help you establish operating conditions, which will permit safe and efficient use of this device.*



## 2.1 Scope of delivery

**INFORMATION!**

*Inspect the packaging carefully for damages or signs of rough handling. Report damage to the carrier and to the local office of the manufacturer.*

**INFORMATION!**

*Do a check of the packing list to make sure that you have all the elements given in the order.*

**INFORMATION!**

*Look at the device nameplate to ensure that the device is delivered according to your order. Check for the correct supply voltage printed on the nameplate.*

**The following items are supplied with the device:**

- Measuring device in ordered version
- For mechanical connections DIN 3852: O-ring (pre-assembled)
- Product documentation

**INFORMATION!**

*Assembly materials and tools are not part of the delivery. Use the assembly materials and tools in compliance with the applicable occupational health and safety directives.*

## 2.2 Nameplate



### INFORMATION!

Look at the device nameplate to ensure that the device is delivered according to your order. Check for the correct supply voltage printed on the nameplate.

The device can be identified by its nameplate. It provides the most important data.

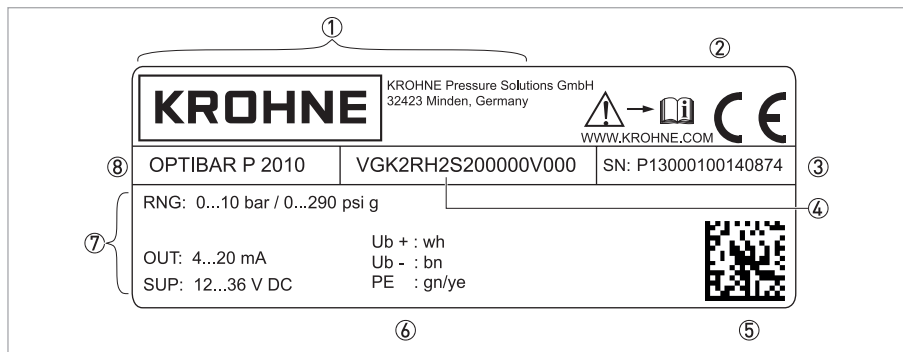

Figure 2-1: Example for nameplate

- ① Manufacturer logo and address
- ② CE marking and other approvals (e.g. ATEX, PED,...)
- ③ Serial number
- ④ Type code
- ⑤ Barcode
- ⑥ Electrical connection diagram
- ⑦ Specifications for process conditions (measuring range, MWP [= Maximum Working Pressure] and electrical data (signal output and power supply))
- ⑧ Product name

### 3.1 General notes on installation

**INFORMATION!**

*Inspect the packaging carefully for damages or signs of rough handling. Report damage to the carrier and to the local office of the manufacturer.*

**INFORMATION!**

*Do a check of the packing list to make sure that you have all the elements given in the order.*

**INFORMATION!**

*Look at the device nameplate to ensure that the device is delivered according to your order. Check for the correct supply voltage printed on the nameplate.*

### 3.2 Installation specifications

**WARNING!**

*Install the device only when depressurised and without power!*

**DANGER!**

*For installation the respective regulations for explosion protection have to be fulfilled.*

**INFORMATION!**

*For installations outdoor and in damp areas, the following points must be observed:*

- To ensure that no moisture can get into the connector, the device should be connected electrically immediately after installation. Otherwise a moisture admission has to be prevented e.g. by using a suitable protection cap.*
- Select an installation if possible, where a mounting position allows draining of spray and condensate. Sealing surfaces should not be submerged!*
- When using devices with cable glands or output, the cable should be looped facing down so that any liquid that collects on the cable can drip off.*
- Install the device so it is protected from direct sunlight. In the worst case scenario, the permissible operating temperature will be exceeded in the presence of direct sunlight. This can negatively affect or damage the functionality of the device. In addition, it can lead to temporary measuring errors if the internal pressure of the device increases due to the sunlight.*
- When installing outside where the risk of lightning or overvoltage may exist and damage the device, we recommend installing suitable overvoltage protection between the supply device or control cabinet and the device.*

**INFORMATION!**

- *Handle this highly sensitive electronic measuring device with care, both in and out of the packaging!*
- *Only remove the packaging and any protection cap from the device immediately before installing to prevent damage to the diaphragm! Keep the supplied protection cap! Remove the protection cap slowly and carefully to avoid any negative pressure on the diaphragm.*
- *Handle the unprotected diaphragm with extreme care; it is very easily damaged.*
- *A device with a gauge reference in the housing (small hole next to the electrical connection) must be installed so that the gauge reference necessary for measurement is protected from dirt and moisture. Should the pressure transmitter be exposed to fluid admission, the air pressure compensation is blocked by the gauge reference. Accurate measurement in this state is not possible. It can also result in damage to the pressure transmitter.*
- *Ensure that no mechanical stress is applied to the pressure port during installation as this may result in a shift in the characteristic curve. This applies in particular to very small pressure ranges as well as to devices with plastic pressure ports.*
- *With hydraulic systems, arrange the device so that the pressure port faces up (venting).*

### 3.3 Mounting

**WARNING!**

*Do not screw in using the housing! Tightening this way can cause damage to the rotary mechanism on the housing.*

**CAUTION!**

- *Prior to installing the transmitter, it is essential to verify whether the version of the device on hand completely fulfils the technical and safety requirements of the measuring point. This applies in particular to the measuring range, overpressure resistance, temperature, explosion protection and operating voltage.*
- *Check the materials used for the wetted parts (e.g. gasket, process connection, separating diaphragm etc.) for suitability as regards process compatibility.*
- *The device must not be heated by radiated heat (e.g. exposure to the sun) to an electronics housing surface temperature above the maximum permissible ambient temperature. If it is necessary to prevent damage from heat sources, a heat protection (e.g. sun shade) has to be installed.*

### 3.3.1 Installation steps for connections acc. to DIN 3852



- Make sure that the O-ring fits properly in the intended groove.
- Ensure that the raised face of the receiving part has a smooth surface.
- Screw the device into the thread by hand.
- Devices with wrench flats must be tightened with a wrench. For information on tightening torque refer to the following table.

Wrench size	Tightening torque [Nm]
<b>Wrench size of steel</b>	
G1/4	approx. 5
G1/2	approx. 10
G3/4	approx. 15
G1	approx. 20
G1 1/2	approx. 25
<b>Wrench size of plastic</b>	
All sizes	max. 3

### 3.3.2 Installation steps for connections acc. to EN 837



- When sealing, use a suitable gasket that corresponds to the product and pressure to be measured (e.g. a copper gasket).
- Ensure that the raised face of the receiving part has a smooth surface.
- Screw the device into the thread by hand.
- Then tighten the device with the wrench.

Wrench size	Tightening torque [Nm]
G1/4	approx. 20
G1/2	approx. 50

### 3.3.3 Installation steps for NPT connections



- When sealing, use a suitable sealing agent that is compatible with the product (e.g. PTFE tape).
- Screw the device into the thread by hand.
- Then tighten the device with the wrench.

Wrench size	Tightening torque [Nm]
1/4 NPT	approx. 30
1/2 NPT	approx. 70

### 3.3.4 Installation steps for clamp and Varivent connections

Notes for versions acc. to 3A standard



**INFORMATION!**

*The device must be assembled according to 3A standard 74-06.*

The device has to be installed in the way that drainability (E1.8.1) and demands acc. to L1.1 are met. The device must be installed with the pressure port downwards or to the side.

**The user is responsible for:**

- using a suitable sealing material
- defining adequate service intervals
- using an elastomer sealing material according to 3A standard 18-03 and 21CFR177.2600
- the right dimension of the gasket

Make sure that welding sockets are mounted flush inside the tank.

**General procedure**



- When sealing, use a suitable gasket that corresponds to the product and pressure to be measured.
- Place the gasket on the corresponding fitting.
- Centre the clamp or Varivent connection over the corresponding fitting and gasket.
- Then use a suitable connecting element (e.g. half ring or clamp ring connection) to attach the device according to the manufacturer's specifications.

### 3.3.5 Installation steps for flange connections



- When sealing, use a suitable gasket that corresponds to the product and pressure to be measured (e.g. a fibre gasket)
- Put the gasket between connecting flange and counter flange.
- Then fasten the device using 4 or 8 screws (depending on flange version) to the counter flange.

## 4.1 Safety instructions



**DANGER!**

All work on the electrical connections may only be carried out with the power disconnected.  
Take note of the voltage data on the nameplate!



**DANGER!**

Observe the national regulations for electrical installations!



**DANGER!**

For devices used in hazardous areas, additional safety notes apply; please refer to the Ex documentation.



**WARNING!**

Observe without fail the local occupational health and safety regulations.  
Any work done on the electrical components of the measuring device may only be carried out by properly trained specialists.



**INFORMATION!**

Look at the device nameplate to ensure that the device is delivered according to your order.  
Check for the correct supply voltage printed on the nameplate.

## 4.2 Terminal assignment



**WARNING!**

Install the device only when depressurised and without power!

Electrical connections	ISO 4400	M12x1 (4-pin)	Field housing
-			-
Supply +	1	1	wh (white)
Supply -	2	2	bn (brown)
Shielding	Ground contact	4	gn/ye (green/yellow)

### Devices with cable glands and cable connector

Ensure that the outer diameter of the cable used is within the permissible clamping range. Also ensure that it is sitting firmly in the cable gland with no gaps!

### Devices with ISO 4400 connector

Ensure that the cable connector is properly installed to guarantee the protection category indicated! Ensure that the gasket supplied is installed between the plug and the cable connector. After connecting the cable, fasten the cable connector to the device using the screw.

### Devices with field housing

With these devices, the connection terminals are under the housing cover. To electrically connect the device, the cover must first be unscrewed. Before screwing the cover back on, check the O-ring and raised face on the housing for damage and replace if necessary! Screw the cover back on by hand and ensure that the field housing is firmly closed.

## 4.3 Electrical connection diagram

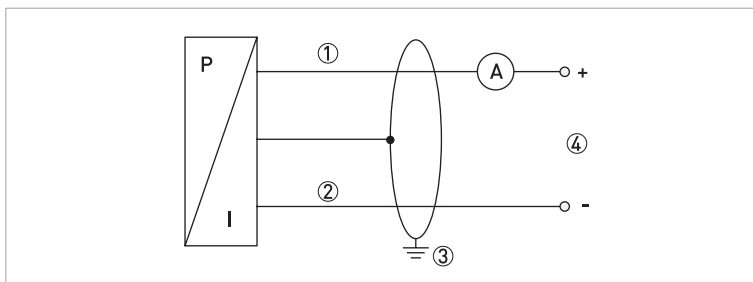

Figure 4-1: Electrical connection diagram 2-wire 4...20 mA

- ① Supply +
- ② Supply -
- ③ Shielding



## 5.1 Maintenance

In principal, the device is maintenance free. If necessary, clean the device housing when switched off using a damp cloth and a non-aggressive cleaning solution.

Depending on the product, deposits or contamination can still occur on the diaphragm. If the product has a known affinity, the operator must determine the cleaning intervals accordingly. Once the device has been properly taken out of commission, the diaphragm can generally be carefully cleaned using a non-aggressive cleaning solution and a soft brush or sponge. If the diaphragm is calcified, decalcification by the manufacturer is recommended.



**INFORMATION!**

*Improper cleaning can result in irreparable damage to the measuring cell. For this reason, never use sharp objects or compressed air to clean the diaphragm.*

## 5.2 Recalibration

During the life cycle of the device, the offset or full-scale of the device may shift. If this occurs, note that the signal value output will deviate based on the set start or end value of the measuring range. If one of these phenomena does occur following prolonged use, recalibration is recommended to ensure continued high accuracy.

## 5.3 Spare parts availability

The manufacturer adheres to the basic principle that functionally adequate spare parts for each device or each important accessory part will be kept available for a period of 3 years after delivery of the last production run for the device.

This regulation only applies to spare parts which are subject to wear and tear under normal operating conditions.

## 5.4 Availability of services

The manufacturer offers a range of services to support the customer after expiration of the warranty. These include repair, maintenance, technical support and training.



**INFORMATION!**

*For more precise information, please contact your local sales office.*

## 5.5 Repairs

Repairs must be carried out exclusively by the manufacturer or the manufacturer authorised specialist companies.

## 5.6 Returning the device to the manufacturer

### 5.6.1 General information

This device has been carefully manufactured and tested. If installed and operated in accordance with these operating instructions, it will rarely present any problems.



**WARNING!**

*Should you nevertheless need to return a device for inspection or repair, please pay strict attention to the following points:*

- *Due to statutory regulations on environmental protection and safeguarding the health and safety of the personnel, the manufacturer may only handle, test and repair returned devices that have been in contact with products without risk to personnel and environment.*
- *This means that the manufacturer can only service this device if it is accompanied by the following certificate (see next section) confirming that the device is safe to handle.*



**WARNING!**

*If the device has been operated with toxic, caustic, radioactive, flammable or water-endangering products, you are kindly requested:*

- *to check and ensure, if necessary by rinsing or neutralising, that all cavities are free from such dangerous substances,*
- *to enclose a certificate with the device confirming that it is safe to handle and stating the product used.*

### 5.6.2 Form (for copying) to accompany a returned device



**CAUTION!**

*To avoid any risk for our service personnel, this form has to be accessible from outside of the packaging with the returned device.*

Company:		Address:	
Department:		Name:	
Telephone number:		Email address:	
Fax number:			
Manufacturer order number or serial number:			
The device has been operated with the following medium:			
This medium is:	<input type="checkbox"/>	radioactive	
	<input type="checkbox"/>	water-hazardous	
	<input type="checkbox"/>	toxic	
	<input type="checkbox"/>	caustic	
	<input type="checkbox"/>	flammable	
	<input type="checkbox"/>	We checked that all cavities in the device are free from such substances.	
	<input type="checkbox"/>	We have flushed out and neutralized all cavities in the device.	
We hereby confirm that there is no risk to persons or the environment caused by any residual media contained in this device when it is returned.			
Date:		Signature:	
Stamp:			

### 5.7 Disposal



**LEGAL NOTICE!**

*Disposal must be carried out in accordance with legislation applicable in your country.*

**Separate collection of WEEE (Waste Electrical and Electronic Equipment) in the European Union:**



According to the directive 2012/19/EU, the monitoring and control instruments marked with the WEEE symbol and reaching their end-of-life **must not be disposed of with other waste.**

The user must dispose of the WEEE to a designated collection point for the recycling of WEEE or send them back to our local organisation or authorised representative.

## 6.1 Technical data



### INFORMATION!

- The following data is provided for general applications. If you require data that is more relevant to your specific application, please contact us or your local sales office.
- Additional information (certificates, special tools, software,...) and complete product documentation can be downloaded free of charge from the website (Downloadcenter).

### Measuring system

Measuring principle	Piezoresistive measuring cell
Application range	Measurement of gauge and absolute pressure in gases and liquids
Measuring range	-1...40 bar / -14.5...580 psi; refer also to chapter "Measuring ranges"

### Measuring accuracy

Reference conditions	Medium: air
	Temperature: ambient temperature
	Ambient pressure: 1013 mbar / 14.7 psi
	Nominal position: vertical, pressure port down
	Power supply: 24 VDC
Pressure type	Gauge pressure / absolute pressure
Measuring accuracy according to IEC 60770 (terminal based) (Hysteresis, non-linearity, non-repeatability)	Nominal pressure ( $P_N$ ) < 0.4 bar / 5.8 psi: $\leq \pm 0.5\%$ of URL
	Nominal pressure ( $P_N$ ) $\geq 0.4$ bar / 5.8 psi: $\leq \pm 0.25\%$ of URL (URL = Upper Range Limit)
Ambient temperature effect on zero and span	Nominal pressure ( $P_N$ ) < 0.4 bar / 5.8 psi: $\leq \pm 1.5\%$ of URL in compensated range of 0...+50°C / +32...+122°F
	Nominal pressure ( $P_N$ ) $\geq 0.4$ bar / 5.8 psi: $\leq \pm 0.75\%$ of URL in compensated range of -20...+85°C / -4...+185°F
	Nominal pressure ( $P_N$ ) = -1...0 bar / -14.5...0 psi: $\leq \pm 0.75\%$ of URL
Long-term stability	$\leq \pm 0.1\%$ of URL within one year under reference conditions
Step response time	< 10 ms (T90)
Vacuum resistance	$P_N > 1$ bar / 14.5 psi: vacuum resistant
	$P_N \leq 1$ bar / 14.5 psi: on request

## Operating conditions

<b>Temperature</b>	
Nominal temperature	-20...+85°C / -4...+185°F
Ambient temperature	-40...+85°C / -40...+185°F
	Ex i zone 0: -20...+60°C / -4...+140°F at $p_{abs} = 0.8...1.1$ bar
	Ex i from zone 1: -20...+70°C / -4...+158°F
Storage temperature	-40...+100°C / -40...+212°F
Medium temperature	Silicone oil: -40...+125°C / -40...+257°F
	Food grade oil: -10...+125°C / +14...+257°F
	With cooling fins (optional):  Silicone oil: $P_N > 0$ barg: -40...+300°C / -40...+572°F; $P_N < 0$ barg: -40...+150°C / -40...+302°F  Food grade oil: $P_N > 0$ barg: -10...+250°C / +14...+482°F; $P_N < 0$ barg: -10...+150°C / +14...+301°F
	CIP/SIP
<b>Other conditions</b>	
Ingress protection acc. to IEC 529 / EN 60529	Connector M16 ISO 4400: IP65
	Connector M12x1, 4-pin: IP67
	Thread M12, housing in 1.4404 / AISI 316L: IP67

## Installation conditions

Mounting position	Any - factory calibration carried out with pressure port down.
Dimensions	For detailed information refer to chapter "Dimensions and weights".
Weight	Min. 200 g / 0.44 lb (depending on pressure port)

## Materials

Housing	Stainless steel 1.4404 / AISI 316L
	Field housing (optional): stainless steel 1.4301 / AISI 304
Cable gland	Nickel-plated brass
Fill fluid	Silicone oil
	Food grade oil with FDA approval (Mobil DTE FM 32; Category Code: H1; NSF Registration No.: 130662)
<b>Wetted parts</b>	
Pressure port	Stainless steel 1.4404 / AISI 316L
Separating diaphragm	Stainless steel 1.4435 / AISI 316L; 2.4819 / Hastelloy® C-276
Gasket	Optional and only for DIN threads
	FKM (medium temperature $\leq +200^\circ\text{C}$ / $+392^\circ\text{F}$ ); FFKM (medium temperature $> +200^\circ\text{C}$ / $+392^\circ\text{F}$ )

Surface roughness	
Turning parts	$R_a \leq 0.8 \mu\text{m}$
Diaphragm	$R_a \leq 0.4 \mu\text{m}$
Weld seams	Approx. $R_a \leq 1.5 \mu\text{m}$

### Process connections

Thread	Thread ISO 228 G1/2", DIN 3852 ( $P_N \geq 1 \text{ bar} / 14.5 \text{ psi}$ ), Thread ISO 228 G3/4", DIN 3852 ( $P_N \geq 600 \text{ mbar} / 8.7 \text{ psi}$ ), Thread ISO 228 G1", DIN 3852; Thread ISO 228 G1", cone Thread ISO228 G1/2" hygienic design; DIN3852 Thread ISO228 G1" hygienic design; DIN3852
Clamp	Clamp DN25 ISO 2852; clamp DN38 ISO 2852; clamp DN51 ISO 2852  Others on request.

### Electrical connection

Output signal	4...20 mA current output; 2-wire
Power supply	Standard: $U_b = 8...32 \text{ VDC}$
	Ex i: $U_b = 10...28 \text{ VDC}$
Safety maximum values (Ex i)	$U_i = 28 \text{ V}$ , $I_i = 93 \text{ mA}$ , $P_i = 660 \text{ mW}$ , $C_i \approx 0 \text{ nF}$ , $L_i \approx 0 \mu\text{H}$ ;  The supply connections have a maximum internal capacity of 27 nF to the housing.
Load	$R_{l\text{max}} = [(V_s - V_{s\text{min}}) / 0.02 \text{ A}] \text{ Ohm}$
Short circuit protection	Continuously
Reverse polarity protection	In the event of reversed connections there is no damage but also no function.
Ripple	Supply: 0.05% FSO / 10 V Load: 0.05% FSO / 1 kOhm
Electrical connection	Connector M16 ISO 4400
	Connector M12x1, 4-pin
	Thread M12, housing 316L

### Approvals and certificates

CE	The device fulfils the statutory requirements of the EU directives. The manufacturer certifies that these requirements have been met by applying the CE marking.
Electromagnetic compatibility (EMC) acc. to EN 61326-1:2013	EMC Directive: 2014/30/EU
	For more information consult the relevant declaration of conformity.
Pressure equipment directive	2014/68/EU
<b>Ex</b>	
ATEX	II 1G Ex ia IIC T4 Ga or II 1D Ex ia IIIC T85°C Da
IECEx	Ex ia IIC T4 Ga or Ex ia IIIC T85°C Da

Other standards and approvals	
Vibration resistance acc. to EN 60068-2-6	G1/2": 20g RMS (25...2000 Hz)
	All except G1/2": 10g RMS (25...2000 Hz)
Shock resistant (impact) according to EN 60068-2-27	G1/2": 500g / 1 ms
	All except G1/2": 100g / 1 ms
Hygienic	3-A approved; FDA approved materials

## 6.2 Dimensions and weights

### Connection plug

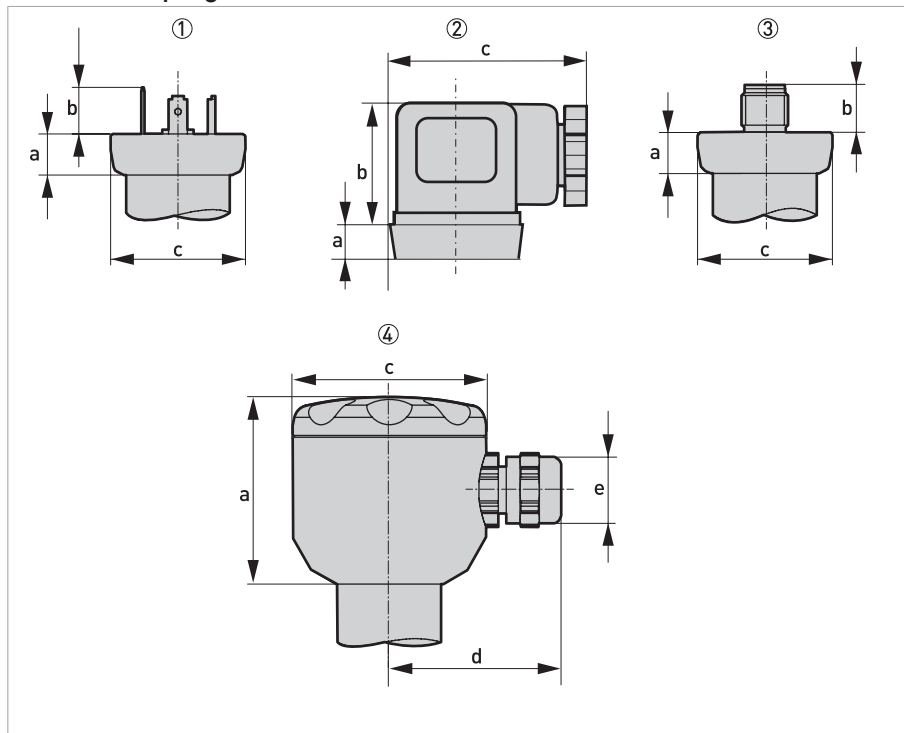

Figure 6-1: Dimensions for connection plug and field housing

- ① ISO 4400 (cable connector is part of delivery)
- ② ISO 4400 (with cable connector)
- ③ M12x1 (4-pin)
- ④ Field housing

	Dimensions							
	①		②		③		④	
	[mm]	["]	[mm]	["]	[mm]	["]	[mm]	["]
a	10.5	0.4	10.5	0.4	10.5	0.4	48	1.9
b	12	0.47	33	1.3	12	0.47	-	-
c	Ø34.5	Ø1.36	Ø50	Ø1.97	Ø34.5	Ø1.36	Ø49.5	Ø1.95
d	-	-	-	-	-	-	44	1.7
e	-	-	-	-	-	-	M12x1.5	

Pressure transmitter with threaded connection

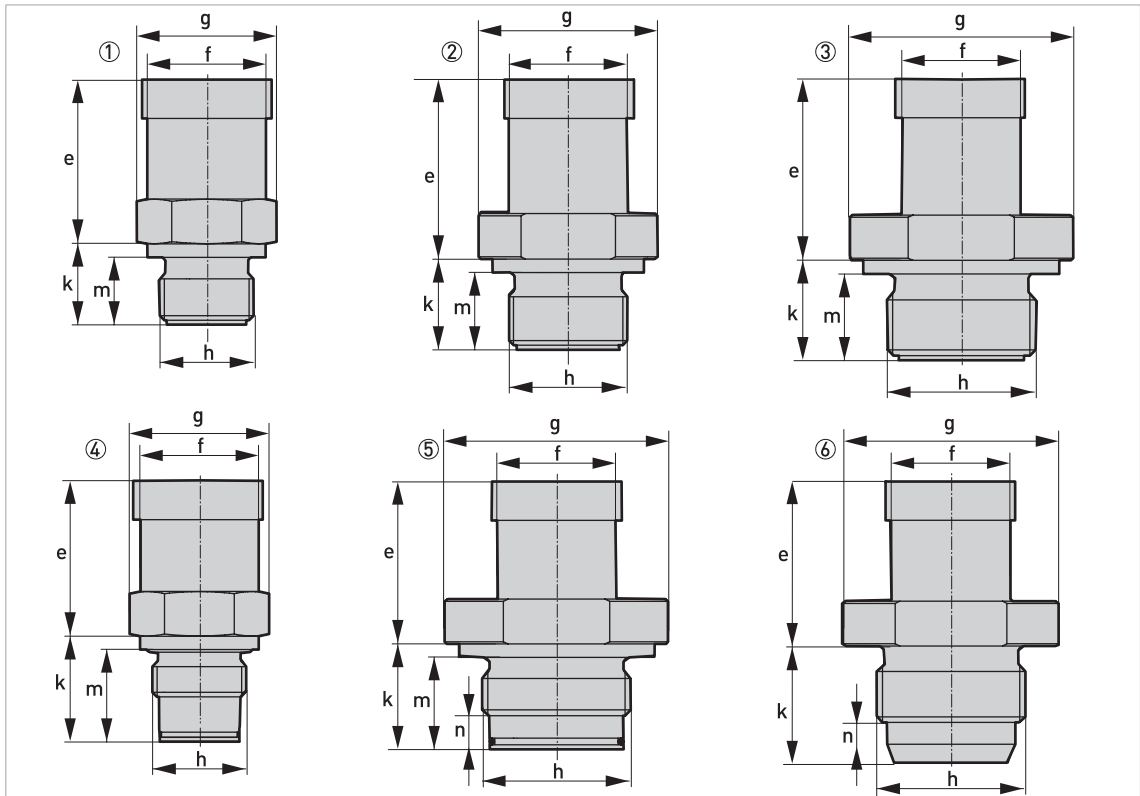

Figure 6-2: Dimensions for pressure transmitter with threaded connection

- ① G1/2" DIN 3852 flush
- ② G3/4" DIN 3852 flush
- ③ G1" DIN 3852 flush
- ④ G1/2" DIN 3852 flush hygienic design
- ⑤ G1" DIN 3852 flush hygienic design
- ⑥ G1" cone

	Dimensions											
	①		②		③		④		⑤		⑥	
	[mm]	[""]	[mm]	[""]	[mm]	[""]	[mm]	[""]	[mm]	[""]	[mm]	[""]
e	60	2.36	60	2.36	60	2.36	60	2.36	60	2.36	60	2.36
f	Ø26.5	Ø1.04	Ø26.5	Ø1.04	Ø26.5	Ø1.04	Ø26.5	Ø1.04	Ø26.5	Ø1.04	Ø26.5	Ø1.04
g	WS27		WS34		WS41		WS27		WS41		WS34	
h	G½"		G¾"		G1"		G½"		G1"		G1"	
k	18	0.71	20	0.79	22	0.87	23.5	0.93	23.5	0.93	26	1.02
m	15	0.59	17	0.67	19	0.75	20.5	0.81	20.5	0.81	-	-
n	-	-	-	-	-	-	-	-	7.5	0.3	9	0.35

The entire length of the device is made up of the electrical connection (a), the transmitter housing (e) and the process connection (k).  
 With cooling fins (optional) additional 32 mm / 1.26".



## Pressure transmitter with cooling fins and hygienic process connections

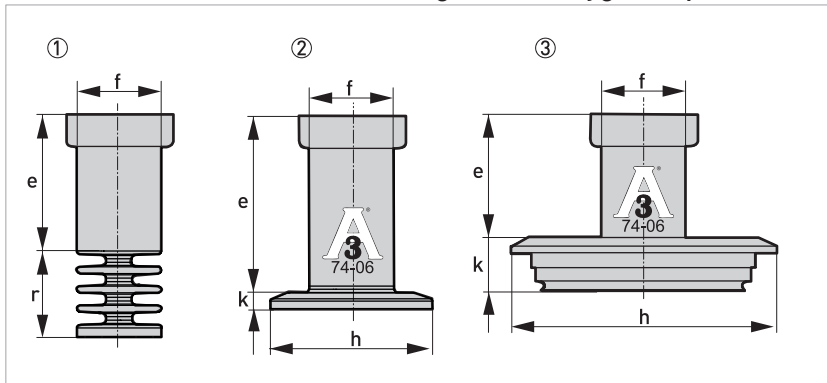

Figure 6-3: Dimensions for pressure transmitter with cooling fins and hygienic process connections

- ① Cooling fins (optional)
- ② Clamp DIN 32678 / ISO 2852, 3-A approved
- ③ Varivent® DN40/50, 3-A approved

	Dimensions					
	①		②		③	
	[mm]	[""]	[mm]	[""]	[mm]	[""]
e	50	1.97	50	1.97	48	1.89
f	Ø26.5	Ø1.04	Ø26.5	Ø1.04	Ø26.5	Ø1.04
h	-	-	DN25: 50.5 DN38: 50.5 DN51: 64	DN25: 2.0 DN38: 2.0 DN51: 2.5	Ø84	Ø3.3
k	-	-	5	0.2	17	0.67
r	32	1.26	-	-	-	-

The entire length of the device is made up of the electrical connection (a), the transmitter housing (e) and the process connection (k).

**INFORMATION!**

*Other hygienic connections are available on request.*

### 6.3 Measuring ranges

#### Pressure in bar

Nominal pressure (gauge/abs.)	0.10	0.16	0.25	0.40	0.50	0.60	1	1.6
Max. working pressure (MWP)	0.5	1	1	2	2	5	5	10
Burst pressure (OPL)	1.5	1.5	1.5	3	3	7.5	7.5	15

Nominal pressure (gauge/abs.)	2	2.5	4	5	6	10	16	25	40
Max. working pressure (MWP)	10	10	20	20	40	40	80	80	105
Burst pressure (OPL)	15	15	25	25	50	50	120	120	210

#### Pressure in psi

Nominal pressure (gauge/abs.)	1.45	2.32	3.63	5.80	7.50	8.70	14.5	23.2
Max. working pressure (MWP)	7.3	14.5	14.5	29	29	72.5	72.5	145
Burst pressure (OPL)	21.8	21.8	21.8	43.5	43.5	108.8	108.8	217.6

Nominal pressure (gauge/abs.)	29	36.3	58.0	72.5	87.0	145	232.1	362.6	580
Max. working pressure (MWP)	145	145	290	290	580	580	1160	1160	1523
Burst pressure (OPL)	217.6	217.6	362.6	362.6	725	725	1740	1740	3046



## KROHNE – Process instrumentation and measurement solutions

- Flow
- Level
- Temperature
- Pressure
- Process Analysis
- Services

Head Office KROHNE Messtechnik GmbH  
Ludwig-Krohne-Str. 5  
47058 Duisburg (Germany)  
Tel.: +49 203 301 0  
Fax: +49 203 301 10389  
info@krohne.com

The current list of all KROHNE contacts and addresses can be found at:  
[www.krohne.com](http://www.krohne.com)

**KROHNE**