

Operating Instructions OPTISOUND 3010 C

4 ... 20 mA/HART - two-wire



Document
ID: 30503

Variable area flowmeters

Vortex flowmeters

Flow controllers

Electromagnetic flowmeters

Ultrasonic flowmeters

Mass flowmeters

Level measuring instruments

Communications engineering

Engineering systems & solutions

Switches, counters, displays and recorders

Heat metering

Pressure and temperature

Contents

1	About this document	
1.1	Function	4
1.2	Target group	4
1.3	Symbols used.....	4
2	For your safety	
2.1	Authorised personnel	5
2.2	Appropriate use.....	5
2.3	Warning about incorrect use.....	5
2.4	General safety instructions	5
2.5	Safety label on the instrument	6
2.6	CE conformity.....	6
2.7	Fulfillment of NAMUR recommendations	6
2.8	Safety instructions for Ex areas	6
3	Product description	
3.1	Configuration.....	7
3.2	Principle of operation.....	8
3.3	Operation	8
3.4	Packaging, transport and storage.....	8
4	Mounting	
4.1	General instructions	10
4.2	Mounting instructions	11
5	Connecting to power supply	
5.1	Preparing the connection	17
5.2	Connection procedure.....	18
5.3	Wiring plan, single chamber housing.....	19
5.4	Wiring plan, double chamber housing	20
5.5	Switch-on phase.....	22
6	Set up with the display and adjustment module	
6.1	Short description	23
6.2	Insert display and adjustment module	23
6.3	Adjustment system	24
6.4	Setup steps	25
6.5	Menu schematic.....	29
6.10	Saving the parameter adjustment data.....	31
7	Maintenance and fault rectification	
7.1	Maintenance	32
7.2	Rectify faults.....	32
7.3	Exchanging the electronics module.....	33
7.4	Instrument repair	33
8	Dismounting	
8.1	Dismounting steps.....	34
8.2	Disposal	34
9	Supplement	
9.1	Technical data	35
9.2	Dimensions	38

Supplementary documentation**Information:**

Supplementary documents appropriate to the ordered version come with the delivery. You can find them listed in chapter "*Product description*".

Editing status: 2014-02-28

1 About this document

1.1 Function

This operating instructions manual provides all the information you need for mounting, connection and setup as well as important instructions for maintenance and fault rectification. Please read this information before putting the instrument into operation and keep this manual accessible in the immediate vicinity of the device.

1.2 Target group

This operating instructions manual is directed to trained specialist personnel. The contents of this manual should be made available to these personnel and put into practice by them.

1.3 Symbols used



Information, tip, note

This symbol indicates helpful additional information.



Caution: If this warning is ignored, faults or malfunctions can result.



Warning: If this warning is ignored, injury to persons and/or serious damage to the instrument can result.



Danger: If this warning is ignored, serious injury to persons and/or destruction of the instrument can result.



Ex applications

This symbol indicates special instructions for Ex applications.



SIL applications

This symbol indicates instructions for functional safety which must be particularly taken into account for safety-relevant applications.



List

The dot set in front indicates a list with no implied sequence.



Action

This arrow indicates a single action.



Sequence of actions

Numbers set in front indicate successive steps in a procedure.



Battery disposal

This symbol indicates special information about the disposal of batteries and accumulators.

2 For your safety

2.1 Authorised personnel

All operations described in this operating instructions manual must be carried out only by trained specialist personnel authorised by the plant operator.

During work on and with the device the required personal protective equipment must always be worn.

2.2 Appropriate use

OPTISOUND 3010 C is a sensor for continuous level measurement.

You can find detailed information about the area of application in chapter "*Product description*".

Operational reliability is ensured only if the instrument is properly used according to the specifications in the operating instructions manual as well as possible supplementary instructions.

For safety and warranty reasons, any invasive work on the device beyond that described in the operating instructions manual may be carried out only by personnel authorised by the manufacturer. Arbitrary conversions or modifications are explicitly forbidden.

2.3 Warning about incorrect use

Inappropriate or incorrect use of the instrument can give rise to application-specific hazards, e.g. vessel overfill or damage to system components through incorrect mounting or adjustment.

2.4 General safety instructions

This is a state-of-the-art instrument complying with all prevailing regulations and guidelines. The instrument must only be operated in a technically flawless and reliable condition. The operator is responsible for the trouble-free operation of the instrument.

During the entire duration of use, the user is obliged to determine the compliance of the necessary occupational safety measures with the current valid rules and regulations and also take note of new regulations.

The safety instructions in this operating instructions manual, the national installation standards as well as the valid safety regulations and accident prevention rules must be observed by the user.

For safety and warranty reasons, any invasive work on the device beyond that described in the operating instructions manual may be carried out only by personnel authorised by the manufacturer. Arbitrary conversions or modifications are explicitly forbidden.

The safety approval markings and safety tips on the device must also be observed.

2.5 Safety label on the instrument

The safety approval markings and safety tips on the device must be observed.

2.6 CE conformity

The device fulfills the legal requirements of the applicable EC guidelines. By affixing the CE marking, we confirm successful testing of the product.

2.7 Fulfillment of NAMUR recommendations

NAMUR is the automation technology user association in the process industry in Germany. The published NAMUR recommendations are accepted as the standard in field instrumentation.

The device fulfills the requirements of the following NAMUR recommendations:

- NE 21 – Electromagnetic compatibility of equipment
- NE 43 – Signal level for malfunction information from measuring transducers
- NE 53 – Compatibility of field devices and display/adjustment components

For further information see www.namur.de.

You can find all software histories on our website www.krohne.com.

2.8 Safety instructions for Ex areas

Please note the Ex-specific safety information for installation and operation in Ex areas. These safety instructions are part of the operating instructions manual and come with the Ex-approved instruments.

3 Product description

3.1 Configuration

Scope of delivery

The scope of delivery encompasses:

- OPTISOUND 3010 C ultrasonic sensor
- Documentation
 - this operating instructions manual
 - Ex specific safety instructions (with Ex versions), if necessary further certificates
 - Operating instructions manual "Display and adjustment module" (optional)

Constituent parts

The OPTISOUND 3010 C consists of the components:

- Transducer with integrated temperature sensor
- Housing with electronics
- Housing cover with integrated display and adjustment module (optional)

The components are available in different versions.

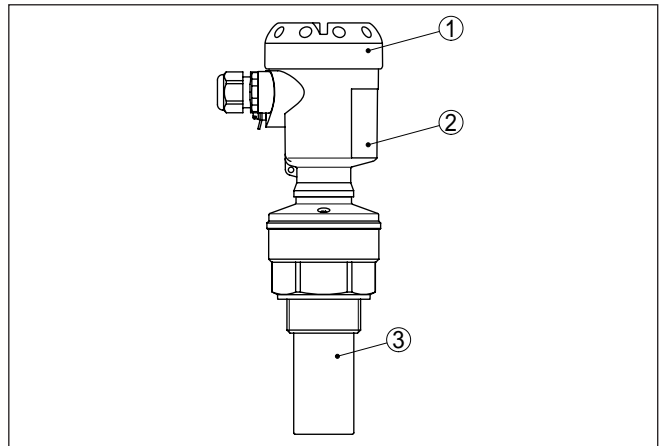

Fig. 1: OPTISOUND 3010 C - version with plastic housing

- 1 Housing cover with integrated display and adjustment module (optional)
- 2 Housing with electronics
- 3 Process fitting with transducer

Type label

The type label contains the most important data for identification and use of the instrument:

- Instrument type
- Article and serial number device
- Article numbers, documentation
- Technical data: For example approvals, process temperature, process fitting/material, signal output, power supply, protection

3.2 Principle of operation

Application area	OPTISOUND 3010 C is an ultrasonic sensor for continuous level measurement. It is suitable for liquids and solids in virtually all industries, particularly in the water and waste water industry.
Functional principle	The transducer of the ultrasonic sensor transmits short ultrasonic pulses to the measured product. These pulses are reflected by product surface and received back by the transducer as echoes. The running time of the ultrasonic pulses from emission to reception is proportional to the distance and hence the level. The determined level is converted into an appropriate output signal and outputted as measured value.
Voltage supply	<p>4 ... 20 mA/HART two-wire electronics for voltage supply and measured value transmission on the same cable.</p> <p>The supply voltage range can differ depending on the instrument version. The exact range is stated in chapter "<i>Technical data</i>".</p> <p>The backlight of the display and adjustment module is powered by the sensor. The prerequisite for this is a supply voltage at a certain level. The exact voltage specifications are stated in chapter "<i>Technical data</i>".</p>
3.3 Operation	
The instrument can be adjusted with the following adjustment media:	
<ul style="list-style-type: none"> ● With the display and adjustment module ● With a HART handheld 	
The entered parameters are generally saved in OPTISOUND 3010 C, optionally also in the indicating/adjustment module.	
3.4 Packaging, transport and storage	
Packaging	<p>Your instrument was protected by packaging during transport. Its capacity to handle normal loads during transport is assured by a test based on ISO 4180.</p> <p>The packaging of standard instruments consists of environment-friendly, recyclable cardboard. For special versions, PE foam or PE foil is also used. Dispose of the packaging material via specialised recycling companies.</p>
Transport	Transport must be carried out in due consideration of the notes on the transport packaging. Nonobservance of these instructions can cause damage to the device.
Transport inspection	The delivery must be checked for completeness and possible transit damage immediately at receipt. Ascertained transit damage or concealed defects must be appropriately dealt with.
Storage	Up to the time of installation, the packages must be left closed and stored according to the orientation and storage markings on the outside.

Unless otherwise indicated, the packages must be stored only under the following conditions:

- Not in the open
- Dry and dust free
- Not exposed to corrosive media
- Protected against solar radiation
- Avoiding mechanical shock and vibration

- Storage and transport temperature see chapter "*Supplement - Technical data - Ambient conditions*"
- Relative humidity 20 ... 85 %

Storage and transport temperature

4 Mounting

4.1 General instructions

Installation position

Select an installation position you can easily reach for mounting and connecting as well as later retrofitting of a display and adjustment module. The housing can be rotated by 330° without the use of any tools. You can also install the display and adjustment module in four different positions (each displaced by 90°).

Moisture

Use the recommended cables (see chapter "Connecting to power supply") and tighten the cable gland.

You can give your OPTISOUND 3010 C additional protection against moisture penetration by leading the connection cable downward in front of the cable entry. Rain and condensation water can thus drain off. This applies mainly to outdoor mounting as well as installation in areas where high humidity is expected (e.g. through cleaning processes) or on cooled or heated vessels.

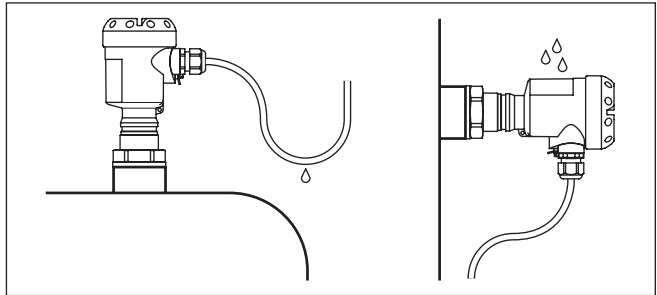

Fig. 2: Measures against moisture penetration

Measuring range

The reference plane for the measuring range is the lower edge of the transducer.

Make sure that a minimum distance from the reference plane - the so-called dead band, in which measurement is not possible - is maintained. The exact value of the dead band is stated in chapter "Technical data".

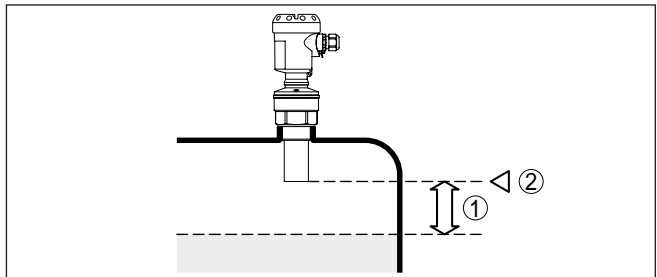

Fig. 3: Minimum distance to the max. level

- 1 Dead band
- 2 Reference plane

**Information:**

If the medium reaches the transducer, buildup can form on it and cause faulty measurements later on.

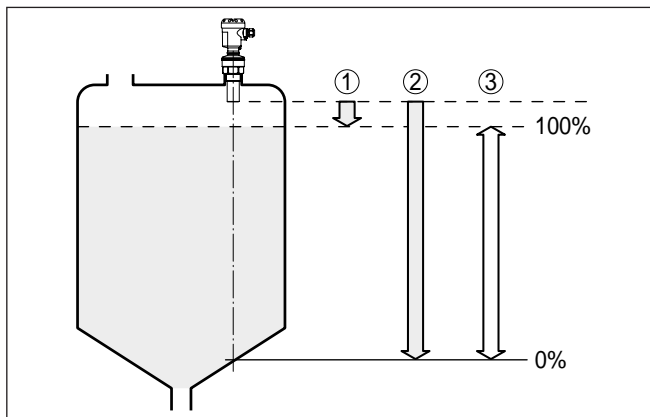

Fig. 4: Measuring range (operating range) and max. measuring distance

- 1 full
- 2 empty (max. measuring distance)
- 3 Measuring range

Pressure/Vacuum

Gauge pressure in the vessel does not influence OPTISOUND 3010 C. Low pressure or vacuum does, however, damp the ultrasonic pulses. This influences the measuring result, particularly if the level is very low. With pressures under -0.2 bar (-20 kPa) you should use a different measuring principle, e.g. radar or guided radar (TDR).

4.2 Mounting instructions**Screwing in**

Screw OPTISOUND 3010 C into the mounting socket with an appropriate spanner applied to the hexagon of the process fitting. Max. torque see chapter "Technical data".

**Warning:**

The housing must not be used to screw the instrument in! Applying tightening force can damage internal parts of the housing.

Installation position

When mounting the OPTISOUND 3010 C, keep a distance of at least 200 mm (7.874 in) to the vessel wall. If the sensor is installed in the center of dished or round vessel tops, multiple echoes can arise. These can, however, be suppressed by an appropriate adjustment (see chapter "Setup").

If you cannot maintain this distance, you should carry out a false signal storage during setup. This applies particularly if buildup on the vessel wall is expected. In such a case, it is recommended to repeat the false signal storage at a later date with existing buildup.

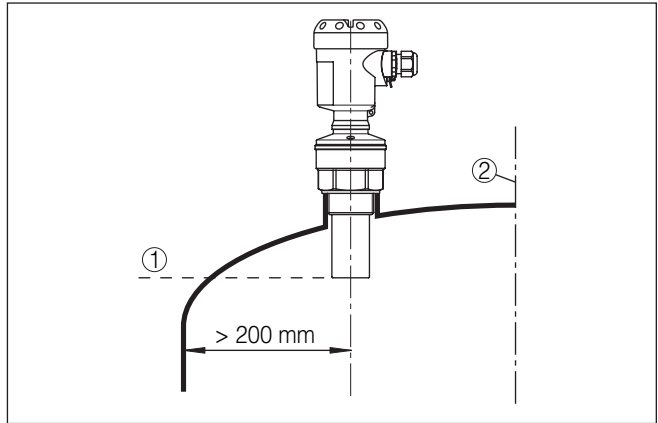

Fig. 5: Mounting on round vessel tops

- 1 Reference plane
- 2 Vessel center or symmetry axis

In vessels with conical bottom it can be advantageous to mount the sensor in the center of the vessel, as measurement is then possible down to the lowest point of the vessel bottom.

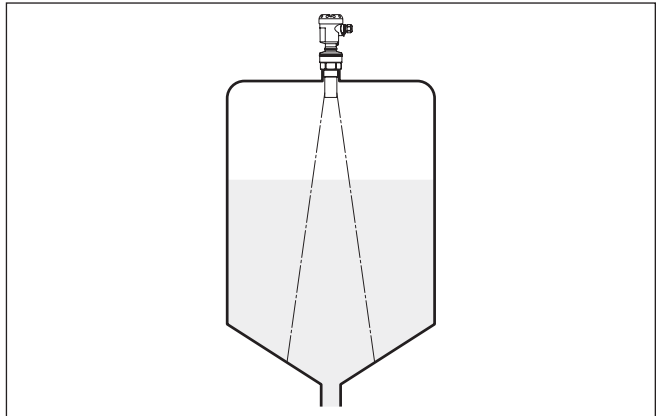

Fig. 6: Vessel with conical bottom

Socket

Socket pieces should be dimensioned so that the lower end of the transducer protrudes at least 10 mm (0.394 in) out of the socket.

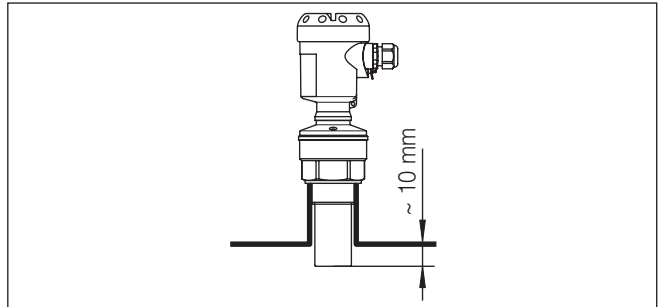

Fig. 7: Recommended socket mounting

If the reflective properties of the medium are good, you can mount OPTISOUND 3010 C on sockets which are higher than the length of the transducer. You will find recommended values for socket heights in the following illustration. The socket end should be smooth and burr-free, if possible also rounded. Carry out a false echo storage.

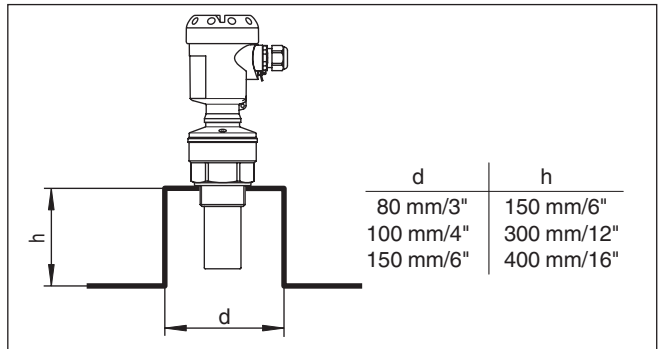

Fig. 8: Deviating socket dimensions

Sensor orientation

In liquids, direct the sensor as perpendicular as possible to the product surface to achieve optimum measurement results.

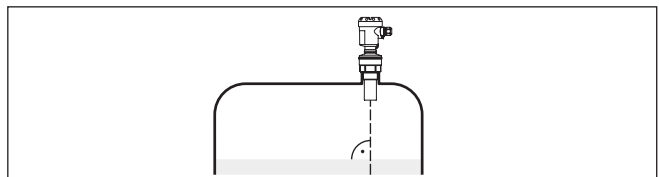

Fig. 9: Alignment in liquids

To reduce the min. distance to the medium, you can also mount OPTISOUND 3010 C with a beam deflector. By doing this, it is possible to fill the vessel nearly to maximum. Such an arrangement is suitable primarily for open vessels such as e.g. overflow basins.

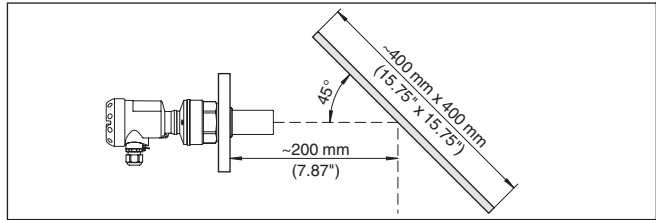

Fig. 10: Beam deflector

Vessel installations

The ultrasonic sensor should be installed at a location where no installations cross the ultrasonic beam.

Vessel installations such as for example, ladders, limit switches, heating spirals, struts etc. can cause false echoes that interfere with the useful echo. Make sure when planning your measuring site that the ultrasonic signals have a "clear view" to the measured product.

In case of existing vessel installations, a false echo storage should be carried out during setup.

If large vessel installations such as struts or supports cause false echoes, these can be attenuated through supplementary measures. Small, inclined sheet metal or plastic baffles above the installations scatter the ultrasonic signals and avoid direct false echoes.

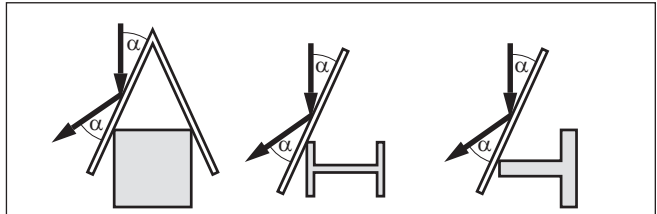

Fig. 11: Cover smooth profiles with deflectors

Agitators

If there are agitators in the vessel, a false signal memory should be carried out with the agitators in motion. This ensures that the interfering reflections from the agitators are saved with the blades in different positions.

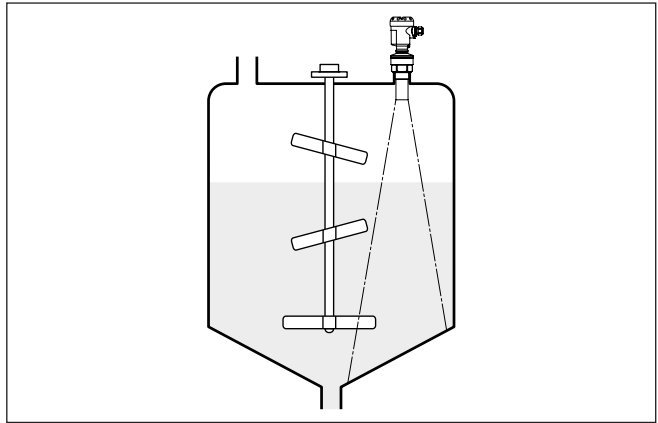

Fig. 12: Agitators

Inflowing medium

Do not mount the instruments in or above the filling stream. Make sure that you detect the product surface, not the inflowing product.

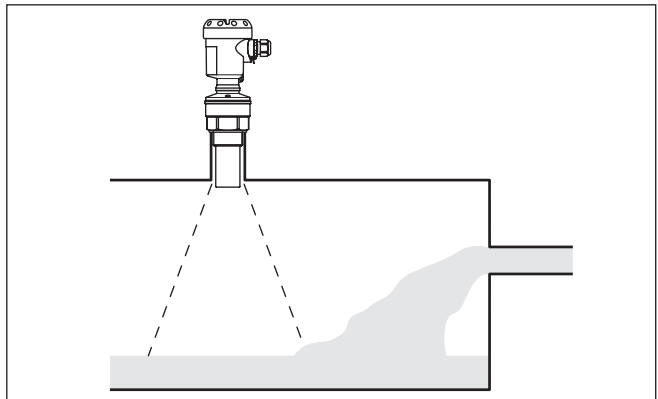

Fig. 13: Inflowing liquid

Foam

Through the action of filling, stirring and other processes in the vessel, dense foams which considerably damp the emitted signals may form on the product surface.

If foams are causing measurement errors, the sensor should be used in a standpipe or, alternatively, the more suitable guided radar sensors (TDR) should be used.

Guided wave radar is unaffected by foam generation and is particularly suitable for such applications.

Air turbulences

If there are strong air currents in the vessel, e.g. due to strong winds in outdoor installations or air turbulence, e.g. by cyclone extraction

you should mount OPTISOUND 3010 C in a standpipe or use a different measuring principle, e.g. radar or guided radar (TDR).

Standpipe measurement

By using a standpipe (surge or bypass tube), the influence of vessel installations, foam generation and turbulence is excluded.

Standpipes must extend all the way down to the requested min. level, as measurement is only possible within the tube.

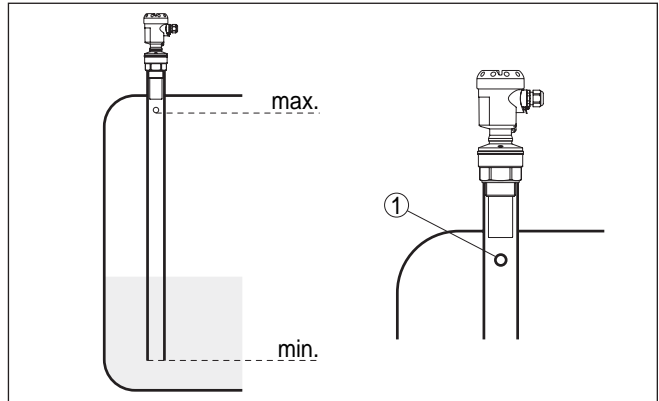

Fig. 14: Standpipe in the tank

1 Vent hole \varnothing 5 ... 10 mm

OPTISOUND 3010 C can be used from tube diameters of 40 mm.

Avoid large gaps and thick welding joints when connecting the tubes. Generally carry out a false echo storage.

Measurement in a standpipe is not recommended for extremely adhesive products.

5 Connecting to power supply

5.1 Preparing the connection

Note safety instructions

Always keep in mind the following safety instructions:

- Connect only in the complete absence of line voltage
- If overvoltage surges are expected, overvoltage arresters should be installed.

Take note of safety instructions for Ex applications



In hazardous areas you must take note of the respective regulations, conformity and type approval certificates of the sensors and power supply units.

Voltage supply

Power supply and current signal are transmitted via the same two-wire connection cable. The supply voltage range can differ depending on the instrument version. The exact range is stated in the "Technical data" in the "Supplement".

Provide a reliable separation between the supply circuit and the mains circuits according to DIN VDE 0106 part 101.

Keep in mind the following additional factors that influence the operating voltage:

- Output voltage of the power supply unit can be lower under nominal load (with a sensor current of 20.5 mA resp. 22 mA in case of fault message)
- Influence of additional instruments in the circuit (see load values in chapter "Technical data")

Connection cable

The instrument is connected with standard two-wire cable without screen. If electromagnetic interference is expected which is above the test values of EN 61326 for industrial areas, screened cable should be used.

Use cable with round cross-section. A cable outer diameter of 5 ... 9 mm (0.2 ... 0.35 in) ensures the seal effect of the cable gland. If you are using cable with a different diameter or cross-section, exchange the seal or use a suitable cable gland.

Cable gland ½ NPT

On the instrument with cable entry ½ NPT and plastic housing there is a metallic ½" threaded insert moulded into the plastic housing.



Caution:

No grease should be used when screwing the NPT cable gland or steel tube into the threaded insert. Standard grease can contain additives that corrode the connection between threaded insert and housing. This would influence the stability of the connection and the tightness of the housing.

Cable screening and grounding

Connect the cable screen on both ends to ground potential. In the sensor, the screen must be connected directly to the internal ground terminal. The ground terminal on the outside of the housing must be connected to the potential equalisation (low impedance).

If potential equalisation currents are expected, the connection on the processing side must be made via a ceramic capacitor (e. g. 1 nF,

**Connection cable
for Ex applications**

1500 V). The low-frequency potential equalisation currents are thus suppressed, but the protective effect against high frequency interference signals remains.

Take note of the corresponding installation regulations for Ex applications. In particular, make sure that no potential equalisation currents flow over the cable screen. In case of grounding on both sides this can be achieved by the use of a capacitor or a separate potential equalisation.

5.2 Connection procedure

Proceed as follows:

1. Unscrew the housing cover
 2. If a display and adjustment module is installed, remove it by turning it slightly to the left.
 3. Loosen compression nut of the cable entry gland
 4. Remove approx. 10 cm (4 in) of the cable mantle, strip approx. 1 cm (0.4 in) of insulation from the ends of the individual wires
 5. Insert the cable into the sensor through the cable entry
 6. Lift the opening levers of the terminals with a screwdriver (see following illustration)
 7. Insert the wire ends into the open terminals according to the wiring plan
 8. Press down the opening levers of the terminals, you will hear the terminal spring closing
 9. Check the hold of the wires in the terminals by lightly pulling on them
 10. Connect the screen to the internal ground terminal, connect the outer ground terminal to potential equalisation
 11. Tighten the compression nut of the cable entry gland. The seal ring must completely encircle the cable
 12. Screw the housing cover back on
- The electrical connection is finished.

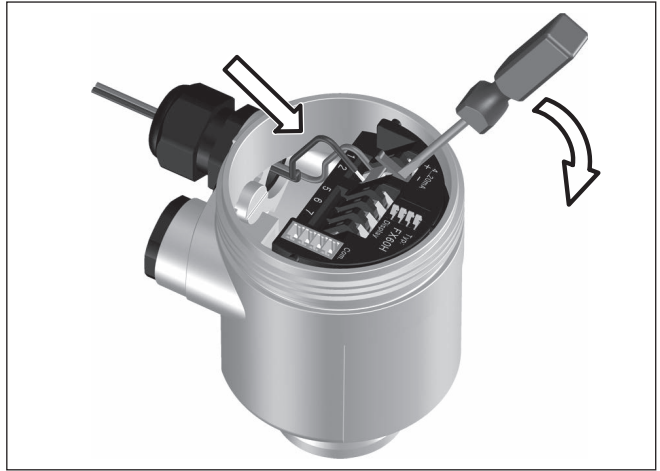

Fig. 15: Connection steps 6 and 7

5.3 Wiring plan, single chamber housing



The following illustrations apply to the non-Ex as well as to the Ex-ia version.

Housing overview

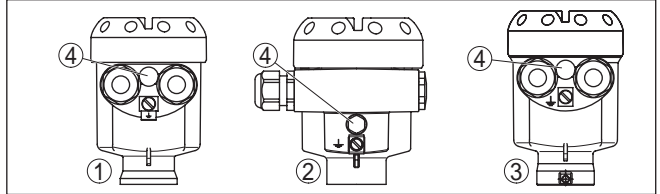

Fig. 16: Material versions, single chamber housing

- 1 Plastic
- 2 Aluminium
- 3 Stainless steel
- 4 Filter element for air pressure compensation

Electronics and terminal compartment

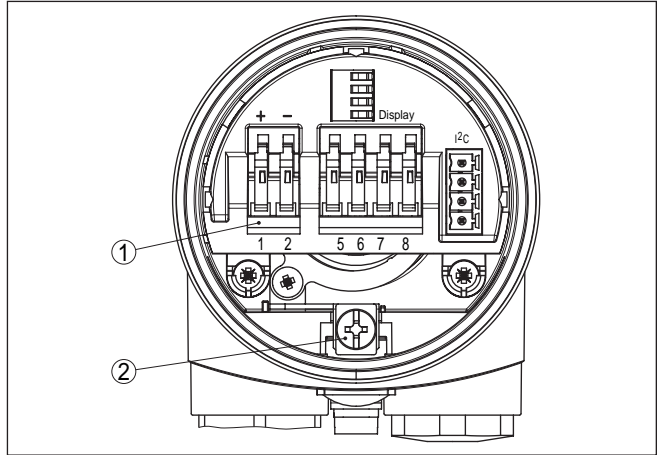

Fig. 17: Electronics and terminal compartment, single chamber housing

- 1 Spring-loaded terminals for voltage supply
- 2 Ground terminal for connection of the cable screen

Wiring plan

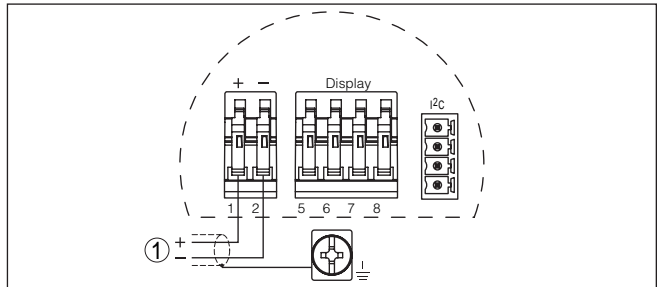

Fig. 18: Wiring plan, single chamber housing

- 1 Voltage supply, signal output

5.4 Wiring plan, double chamber housing



The following illustrations apply to the non-Ex as well as to the Ex-ia version.

Housing overview

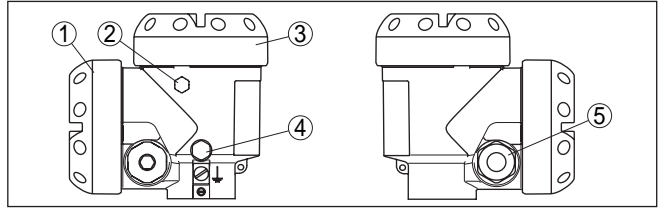

Fig. 19: Double chamber housing

- 1 Housing cover, connection compartment
- 2 Blind plug
- 3 Housing cover, electronics compartment
- 4 Filter element for air pressure compensation
- 5 Cable gland

Electronics compartment

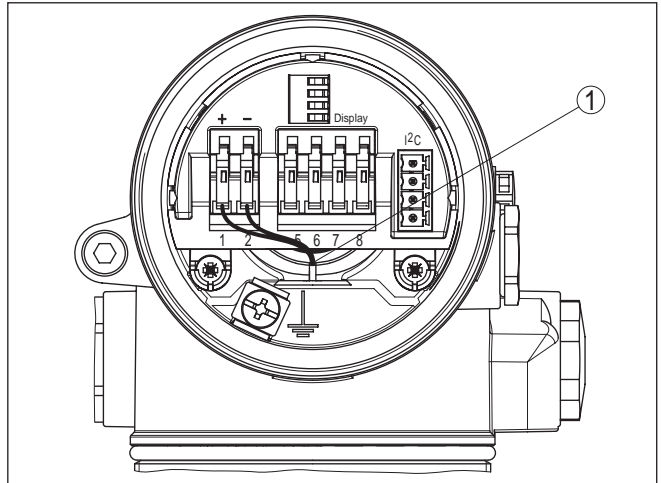

Fig. 20: Electronics compartment, double chamber housing

- 1 Internal connection cable to the connection compartment

Terminal compartment

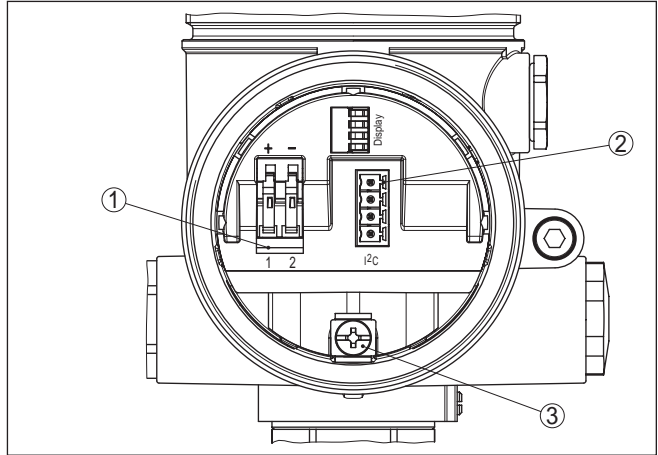

Fig. 21: Terminal compartment, double chamber housing

- 1 Spring-loaded terminals for voltage supply
- 2 Plug connector for service interface
- 3 Ground terminal for connection of the cable screen

Wiring plan

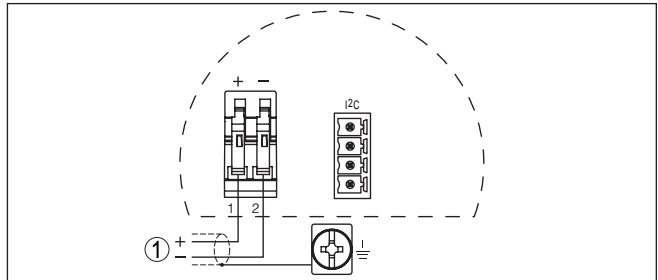

Fig. 22: Wiring plan, double chamber housing

- 1 Voltage supply, signal output

5.5 Switch-on phase

Switch-on phase

After connecting OPTISOUND 3010 C to power supply or after a voltage recurrence, the instrument carries out a self-check for approx. 30 seconds:

- Internal check of the electronics
- Indication of the instrument type, the firmware as well as the sensor TAGs (sensor designation)
- Output signal jumps briefly (approx. 10 seconds) to the set fault current

Then the corresponding current is outputted to the cable (the value corresponds to the actual level as well as the settings already carried out, e.g. factory setting).

6 Set up with the display and adjustment module

6.1 Short description

The display/adjustment module is used for measured value display, adjustment and diagnosis. It can be mounted in all sensors of the OPTISOUND instrument family, in the single as well as double chamber housing (optionally in the electronics or connection compartment).

6.2 Insert display and adjustment module

The display and adjustment module can be inserted into the sensor and removed again at any time. It is not necessary to interrupt the power supply.

Proceed as follows for mounting the display and adjustment module:

1. Unscrew the housing cover
2. Place the display and adjustment module in the desired position on the electronics (you can choose any one of four different positions - each displaced by 90°)
3. Press the display and adjustment module onto the electronics and turn it to the right until it snaps in.
4. Screw housing cover with inspection window tightly back on

Removal is carried out in reverse order.

The display and adjustment module is powered by the sensor, an additional connection is not necessary.

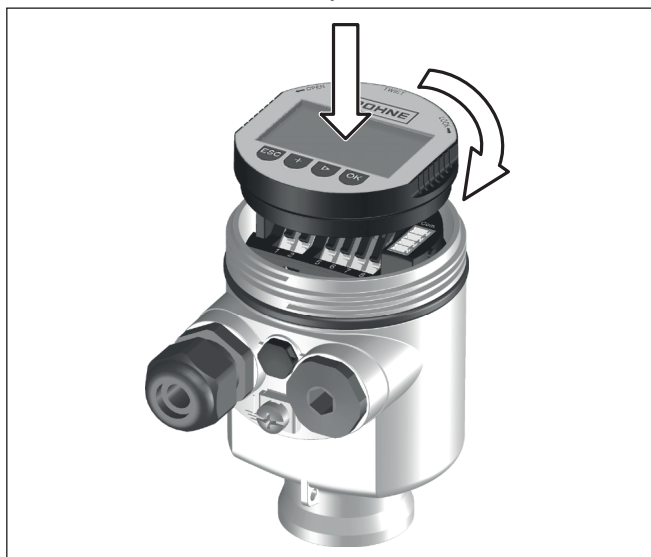

Fig. 23: Insert display and adjustment module

**Note:**

If you intend to retrofit the instrument with a display and adjustment module for continuous measured value indication, a higher cover with an inspection glass is required.

6.3 Adjustment system

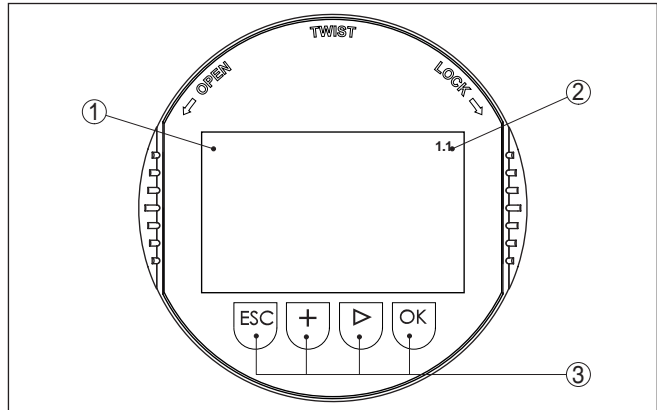

Fig. 24: Display and adjustment elements

- 1 LC display
- 2 Indication of the menu item number
- 3 Adjustment keys

Key functions

- **[OK]** key:
 - Move to the menu overview
 - Confirm selected menu
 - Edit parameter
 - Save value
- **[->]** key to select:
 - Menu change
 - Select list entry
 - Select editing position
- **[+]** key:
 - Change value of the parameter
- **[ESC]** key:
 - Interrupt input
 - Jump to next higher menu

Adjustment system

The sensor is adjusted via the four keys of the display and adjustment module. The LC display indicates the individual menu items. The functions of the individual keys are shown in the above illustration. Approx. 10 minutes after the last pressing of a key, an automatic reset to measured value indication is triggered. Any values not confirmed with **[OK]** will not be saved.

Address setting HART multidrop

6.4 Setup steps

In HART-Multidrop mode (several sensors on one input) the address must be set before continuing with the parameter adjustment. You will find a detailed description in the operating instructions manual of the "Display and adjustment module".

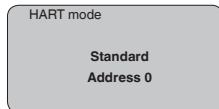

Parameter adjustment

As OPTISOUND 3010 C is a distance measuring instrument, the distance from the sensor to the product surface is measured. To have the real product level displayed, an allocation of the measured distance to the percentage height must be made. To carry out this adjustment, the distance is entered with full and empty vessel. If these values are not known, an adjustment with the distance values, e.g. 10 % and 90 % is also possible. Starting point for these distance specifications is always the lower side of the flange, with all other versions the lower side of the transducer.

The actual level is then calculated on the basis of these entered values. At the same time, the operating range of the sensor is limited from maximum range to the requested range.

The real product level during this adjustment is not important, because the min./max. adjustment is always carried out without changing the product level. These settings can be made ahead of time without the instrument having to be installed.

In the main menu item "Basic adjustment", the individual submenu items should be selected one after the other and provided with the correct parameter values.

Start your parameter adjustment with the following menu items of the basic adjustment:

Carry out min. adjustment Proceed as follows:

1. Move from the measured value display to the main menu by pushing **[OK]**.

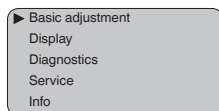

2. Select the menu item "Basic adjustment" with **[->]** and confirm with **[OK]**. Now the menu item "Min. adjustment" is displayed.

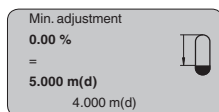

3. Prepare the % value for editing with **[OK]** and set the cursor to the requested position with **[->]**. Set the requested percentage value

with **[+]** and save with **[OK]**. The cursor jumps now to the distance value.

4. Enter the suitable distance value in m for the empty vessel (e.g. distance from the sensor to the vessel bottom) corresponding to the percentage value.
5. Save the settings with **[OK]** and move to "Max. adjustment" with **[->]**.

Carry out max. adjustment

Proceed as follows:

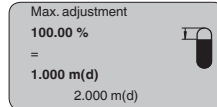

1. Prepare the % value for editing with **[OK]** and set the cursor to the requested position with **[->]**. Set the requested percentage value with **[+]** and save with **[OK]**. The cursor jumps now to the distance value.
2. Enter the appropriate distance value in m (corresponding to the percentage value) for the full vessel. Keep in mind that the max. level must lie below the dead band.
3. Save the settings with **[OK]** and move to "Medium selection" with **[->]**.

Medium selection

Each product has different reflective properties. In addition, there are various interfering factors which have to be taken into account: agitated product surfaces and foam generation (with liquids); dust generation, material cones and echoes from the vessel wall (with solids). To adapt the sensor to these different conditions, you should first select "Liquid" or "Solid".

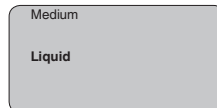

With solids, you can also choose between "Powder/Dust", "Granular/Pellets" or "Ballast/Pebbels".

Through this additional selection, the sensor is adapted perfectly to the product and measurement reliability, particularly in products with poor reflective properties, is considerably increased.

Enter the requested parameters via the appropriate keys, save your settings and jump to the next menu item with the **[->]** key.

Vessel form

Apart from the medium, the vessel shape can also influence the measurement. To adapt the sensor to these measuring conditions, this menu item offers different options depending on whether liquid or bulk solid is selected. With "Liquids" these are "Storage tank", "Stilling tube", "Open vessel" or "Stirred vessel", with "Solid", "Silo" or "Bunker".

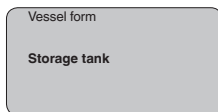

Enter the requested parameters via the appropriate keys, save your settings and jump to the next menu item with the **[→]** key.

Damping

To suppress fluctuations in the measured value display, e. g. caused by an agitated product surface, a damping can be set. This time can be between 0 and 999 seconds. Keep in mind that the reaction time of the entire measurement will then be longer and the sensor will react to measured value changes with a delay. In general, a period of a few seconds is sufficient to smooth the measured value display.

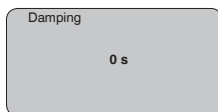

Enter the requested parameters via the appropriate keys, save your settings and jump to the next menu item with the **[→]** key.

Linearisation curve

A linearisation is necessary for all vessels in which the vessel volume does not increase linearly with the level - e.g. in a horizontal cylindrical or spherical tank - and the indication or output of the volume is required. Corresponding linearisation curves are preprogrammed for these vessels. They represent the correlation between the level percentage and vessel volume. By activating the appropriate curve, the volume percentage of the vessel is displayed correctly. If the volume should not be displayed in percent but e.g. in l or kg, a scaling can be also set in the menu item "Display".

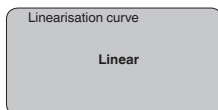

Enter the requested parameters via the appropriate keys, save your settings and jump to the next menu item with the **[→]** key.

Sensor-TAG

In this menu item you can enter an unambiguous designation for the sensor, e.g. the measurement loop name or the tank or product designation. In digital systems and in the documentation of larger plants, a singular designation should be entered for exact identification of individual measuring points.

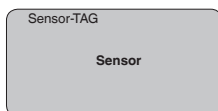

With this menu item, the Basic adjustment is finished and you can now jump to the main menu with the **[ESC]** key.

False signal suppression High sockets or vessel installations, such as e. g. struts or agitators as well as buildup and weld joints on the vessel walls, cause interfering reflections which can impair the measurement. A false echo storage detects and marks these false echoes, so that they are no longer taken into account for the level measurement. A false echo memory should be created with low level so that all potential interfering reflections can be detected.

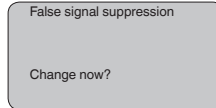

Proceed as follows:

1. Move from the measured value display to the main menu by pushing **[OK]**.
2. Select the menu item "Service" with **[->]** and confirm with **[OK]**. Now the menu item "False signal suppression" is displayed.
3. Confirm "False signal suppression - Change now" with **[OK]** and select in the below menu "Create new". Enter the actual distance from the sensor to the product surface. All false signals in this area are detected by the sensor and saved after confirming with **[OK]**.



Note:

Check the distance to the product surface, because if an incorrect (too large) value is entered, the existing level will be saved as a false echo. The filling level would then no longer be detectable in this area.

Reset

Basic adjustment

If the function "Reset" is carried out, the sensor resets the values of the following menu items to the reset values (see chart):¹⁾

Function	Reset value
Sensor address	126
Max. adjustment	0 m(d)
Min. adjustment	Meas. range end in m(d) ²⁾
Medium	Liquid
Vessel form	not known
Damping	0 s
Linearization	Linear
Sensor-TAG	Sensor
Displayed value	Distance
Current output - characteristics	4 ... 20 mA
Current output - max. current	20 mA
Current output - min. current	4 mA

¹⁾ Sensor-specific basic adjustment.

²⁾ Depending on the sensor type, see chapter "Technical data".

Function	Reset value
Current output - failure	< 3.6 mA
Unit of measurement	m(d)

The values of the following menu items are *not* reset to the reset values (see chart) with "Reset":

Function	Reset value
Backlight	No reset
Language	No reset
HART mode	No reset

Default setting

Like basic adjustment, but in addition, special parameters are reset to default values.³⁾

Peak value indicator

The min. and max. distance and temperature values are reset to the actual value.

Optional settings

Additional adjustment and diagnosis options such as e.g. scaling, simulation or trend curve presentation are shown in the following menu schematic. You will find a detailed description of these menu items in the operating instructions manual "Display and adjustment module".

6.5 Menu schematic

Basic adjustment

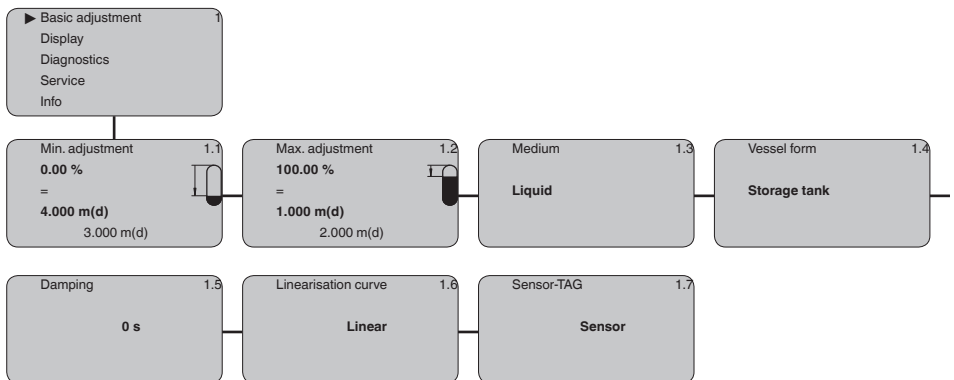

³⁾ Special parameters are parameters which are set customer-specifically on the service level with the adjustment software PACTware.

Display

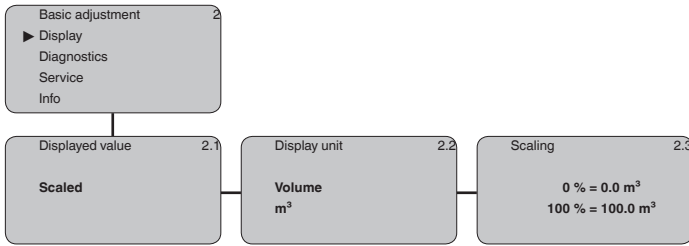

Diagnostics

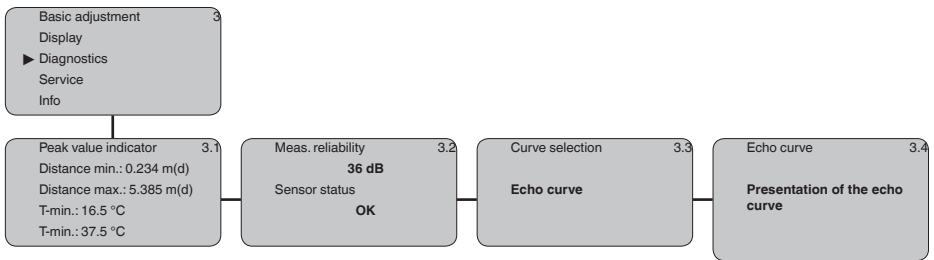

Service

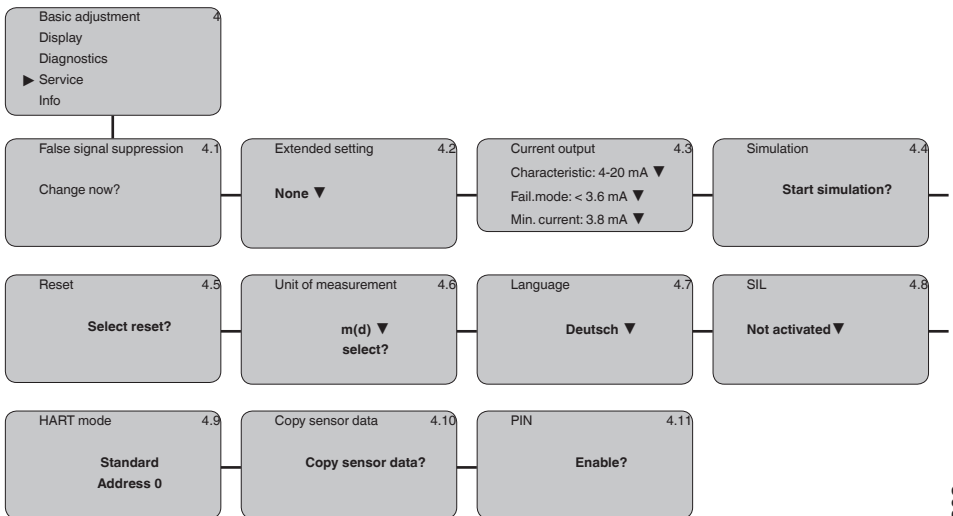

Info

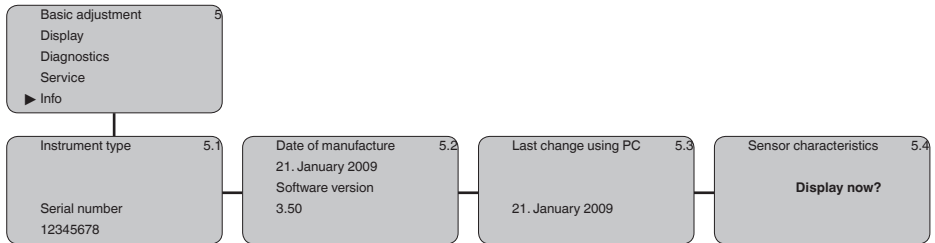

6.10 Saving the parameter adjustment data

We recommend noting the adjusted data, e.g. in this operating instructions manual, and archiving them afterwards. They are thus available for multiple use or service purposes.

If OPTISOUND 3010 C is equipped with a display and adjustment module, the most important data can be read out of the sensor into the display and adjustment module. The procedure is described in the operating instructions manual "*Display and adjustment module*" in the menu item "*Copy sensor data*". The data remain there permanently even if the sensor power supply fails.

If it is necessary to exchange the sensor, the display and adjustment module is inserted into the replacement instrument and the data are written into the sensor under the menu item "*Copy sensor data*".

7 Maintenance and fault rectification

7.1 Maintenance

If the instrument is used properly, no special maintenance is required in normal operation.

7.2 Rectify faults

Reaction when malfunctions occur

The operator of the system is responsible for taking suitable measures to rectify faults.

Failure reasons

OPTISOUND 3010 C offers maximum reliability. Nevertheless, faults can occur during operation. These may be caused by the following, e.g.:

- Sensor
- Process
- Voltage supply
- Signal processing

Fault rectification

The first measures to be taken are to check the output signal and evaluate fault messages via the display/adjustment module. The procedure is described below.

Check the 4 ... 20 mA signal

Connect a multimeter in the suitable measuring range according to the wiring plan. The following table describes possible errors in the current signal and helps to remove them:

Error	Cause	Rectification
4 ... 20 mA signal not stable	Level fluctuations	Set damping via the display and adjustment module
4 ... 20 mA signal missing	Electrical connection faulty	Check connection according to chapter " <i>Connection steps</i> " and if necessary, correct according to chapter " <i>Wiring plan</i> "
	Voltage supply missing	Check cables for breaks; repair if necessary
	Operating voltage too low or load resistance too high	Check, adapt if necessary
Current signal greater than 22 mA or less than 3.6 mA	Electronics module in the sensor defective	Exchange the instrument or send it in for repair



In Ex applications, the regulations for the wiring of intrinsically safe circuits must be observed.

Error messages via the display and adjustment module

Error code	Cause	Rectification
E013	no measured value available	<ul style="list-style-type: none"> – Sensor in boot phase – Sensor does not find an echo, e.g. due to faulty installation or wrong parameter adjustment

Error code	Cause	Rectification
E017	Adjustment span too small	– Carry out a fresh adjustment and increase the distance between min. and max. adjustment
E036	no operable sensor software	– Carry out a software update or send instrument for repair
E041	Hardware error, electronics defective	– Exchange the instrument or send it in for repair

Reaction after fault rectification

Depending on the reason for the fault and the measures taken, the steps described in chapter "Set up" may have to be carried out again.

7.3 Exchanging the electronics module

If the electronics module is defective, it can be replaced by the user.



In Ex applications, only instruments and electronics modules with appropriate Ex approval may be used.

If there is no electronics module available on site, one can be ordered from the Krohne agency serving you.

7.4 Instrument repair

If a repair is necessary, please proceed as follows:

On our homepage in the Internet under

http://www.krohne-mar.com/fileadmin/media-lounge/PDF-Download/Specimen_e.pdf

you can download a return form.

By doing this you help us carry out the repair quickly and without having to call back for needed information.

- Print and fill out one form per instrument
- Clean the instrument and pack it damage-proof
- Attach the completed form and possibly also a safety data sheet to the instrument

8 Dismounting

8.1 Dismounting steps

**Warning:**

Before dismounting, be aware of dangerous process conditions such as e.g. pressure in the vessel or pipeline, high temperatures, corrosive or toxic products etc.

Take note of chapters "*Mounting*" and "*Connecting to power supply*" and carry out the listed steps in reverse order.

8.2 Disposal

The instrument consists of materials which can be recycled by specialised recycling companies. We use recyclable materials and have designed the parts to be easily separable.

WEEE directive 2002/96/EG

This instrument is not subject to the WEEE directive 2002/96/EG and the respective national laws. Pass the instrument directly on to a specialised recycling company and do not use the municipal collecting points. These may be used only for privately used products according to the WEEE directive.

Correct disposal avoids negative effects on humans and the environment and ensures recycling of useful raw materials.

Materials: see chapter "*Technical data*"

If you have no way to dispose of the old instrument properly, please contact us concerning return and disposal.

9 Supplement

9.1 Technical data

General data

Materials, wetted parts

- Process fitting, transducer PVDF
- Seal between transducer and process fitting EPDM, FKM

Materials, non-wetted parts

- Housing Plastic PBT (polyester), Alu die-casting powder-coated, 316L
- Seal between housing and housing cover NBR (stainless steel housing), silicone (Alu/plastic housing)
- Inspection window in housing cover Polycarbonate
- Ground terminal 316Ti/316L

Weight 1.8 ... 4 kg (4 ... 8.8 lbs), depending on the process fitting and housing

Max. torque mounting boss 25 Nm

Output variable

Output signal 4 ... 20 mA/HART

HART output values

- HART value (Primary Value) Distance to the level
- HART value (Secondary Value) Temperature
- HART value (3rd Value) Distance to the level - scaled

Signal resolution 1.6 μ A

Failure signal current output (adjustable) mA-value unchanged 20.5 mA, 22 mA, < 3.6 mA

Current limitation 22 mA

Load see load diagram under Power supply

Damping (63 % of the input variable) 0 ... 999 s, adjustable

Met NAMUR recommendation NE 43

Input variable

Measured variable distance between lower edge of the transducer and product surface

Measuring range

- Liquids up to 5 m (16.4 ft)
- Bulk solids up to 2 m (6.562 ft)

Dead band 0.25 m (0.82 ft)

Reference conditions to measuring accuracy (according to DIN EN 60770-1)

Reference conditions according to DIN EN 61298-1

- Temperature +18 ... +30 °C (+64 ... +86 °F)

- Relative humidity 45 ... 75 %
- Air pressure 860 ... 1060 mbar/86 ... 106 kPa (12.5 ... 15.4 psig)

Other reference conditions

- Reflector ideal reflector, e.g. metal plate 2 x 2 m (6.56 x 6.56 ft)
- False reflections Biggest false signal, 20 dB smaller than the useful signal

Measuring characteristics

Ultrasonic frequency	70 kHz
Interval	> 2 s (dependent on the parameter adjustment)
Abstrahlwinkel at -3 dB	11°
Step response or adjustment time ⁴⁾	> 3 s (dependent on the parameter adjustment)

Measuring accuracy

Resolution, general	max. 1 mm
Deviation	see diagram

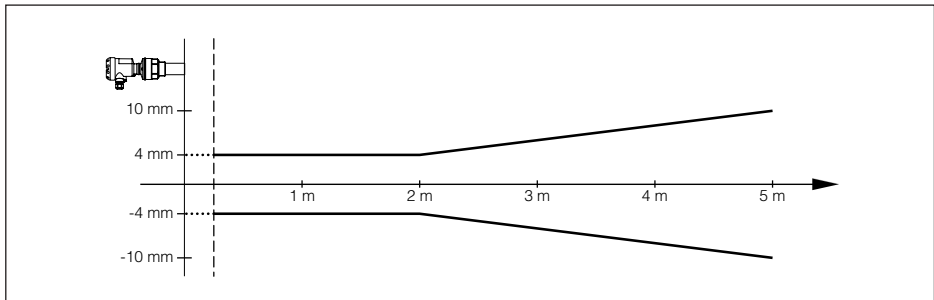

Fig. 25: Deviation OPTISOUND 3010 C

Influence of the ambient temperature to the sensor electronics⁵⁾

Average temperature coefficient of the zero signal (temperature error) 0.06 %/10 K

Ambient conditions

Ambient, storage and transport temperature -40 ... +80 °C (-40 ... +176 °F)

Process conditions

Process pressure	-20 ... 200 kPa/-0.2 ... 2 bar (-2.9 ... 29 psig)
Process temperature (transducer temperature)	
- Seal EPDM	-40 ... +80 °C (-40 ... +176 °F)
- Seal FKM	-20 ... +80 °C (-4 ... +176 °F)

⁴⁾ Time to output the correct level (with max. 10 % deviation) after a sudden level change.

⁵⁾ Relating to the nominal measuring range.

Electrical protective measures

Protection rating

- Plastic housing IP 66/IP 67 (NEMA 4X)
- Aluminium and stainless steel housing IP 66/IP 68 (0.2 bar), NEMA 6P⁷⁾

Overtoltage category

III

Protection class

II

Approvals

Depending on the version, instruments with approvals can have different technical data. For these instruments, please note the corresponding approval documents. They are included in the scope of delivery.

9.2 Dimensions

Housing

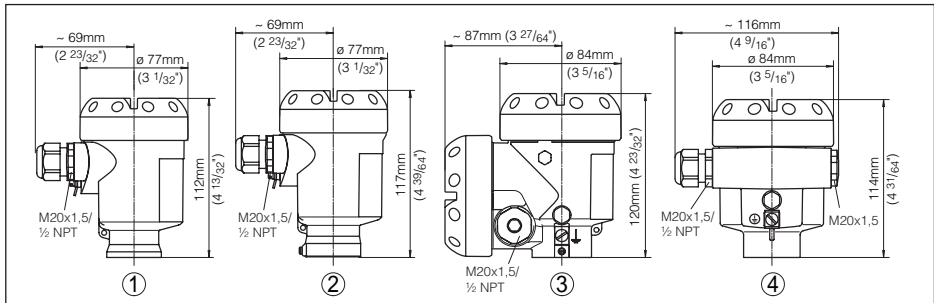

Fig. 26: Housing versions in protection rating IP 66/IP 67 and IP 66/IP 68, 0.2 bar (with integrated display and adjustment module the housing is 9 mm/0.35 in higher or wider)

- 1 Plastic housing
- 2 Stainless steel housing
- 3 Aluminium double chamber housing
- 4 Aluminium housing

⁷⁾ A suitable cable is the prerequisite for maintaining the protection rating.

OPTISOUND 3010 C

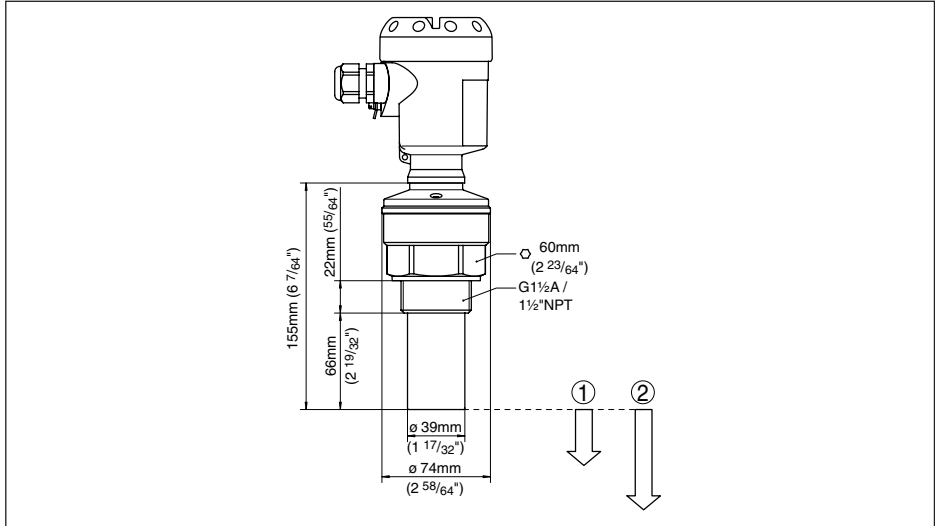

Fig. 27: OPTISOUND 3010 C

- 1 Dead zone: 0.25 m (0.82 ft)
- 2 Measuring range: with liquids up to 5 m (16.4 ft), with solids up to 2 m (6.562 ft)

Subject to change without notice

30503-EN-140310