

KROHNE

03/12

Electromagnetic Flow Switch and Flow Meter

**Installation and
Operating
Instructions**

**DWM 1000
DWM 2000
DWM 2000 L
DWM 2000 IP68**



**KROHNE S.A.
CERTIFIED
ISO 9001**

Contents

	Page
Introduction	3
Special Features	
Measuring Principles	
Components	
Installation	4
Mounting on Pipeline	
Dimensions and Weight	
Electrical Connection and Settings	
DWM1000.....	5
DWM2000.....	6
Compatible Relays (for DWM1000)	7
Version DWM2000 IP68	8
Version DWM2000 Long	
Characteristics	8
Components.....	8
Installation.....	9
Trouble Shooting	10
Technical Data	11
KROHNE Contact Addresses	12

DWM Flow Meters and Switches

The DWM electromagnetic flow meters and switches are designed to measure and monitor the flow rates of electrically conductive liquids, pastes and slurries

Versions

- DWM 1000 flow switch, 2-wire system.
- DWM 2000 flow meter, 4-20 mA current output/readout.
- DWM 2000 L (Long) for flow pipes of greater than 400m diameter or open channels.
- DWM 2000 IP68 for immersed applications.
- DWM 2000 FT for food applications with Tuchenhagen connection (detailed in a separate instructions leaflet).

Special Features

- Rugged design, IP55 protection, equivalent to NEMA 4 and 4X standards.
- All wetted surfaces of ceramic, stainless steel and platinum.
- Compatible with process temperatures up to 150°C (300°F), and ambient temperatures between - 25 à + 60°C
- Suitable for operating pressures up to 25 bar (360psi).
- No moving parts, maintenance free.
- Electronic unit replaceable without interruption of flow.
- Compatible for all pipelines with nominal diameter (DN) 50mm (2").
- Readout connection possible with handheld consoles (DWM 2000 only).

Measuring Principle

If an electrical conductor moves through a magnetic field, a voltage, U , is induced in the conductor. In the case of the DWM, the liquid in the flow pipe is the electrical conductor. In the diagram below, the DWM creates the magnetic field, B , perpendicular to the direction of flow. The induced voltage U is directly proportional to the local flow velocity v .

$$U = k \times B \times v \times D$$

k - Instrument constant
 B - Strength of magnetic field
 v - Flow velocity
 D - Electrode spacing

Voltage U is tapped off from the electrodes, neutral and ground electrode (connection socket)

DWM 1000 Flow Switch - Voltage U is converted into a switching signal with adjustable switching point.

DWM 2000 Flow Meter - Voltage U is converted into a flow-proportional output signal current between 4-20 mA (load independent).

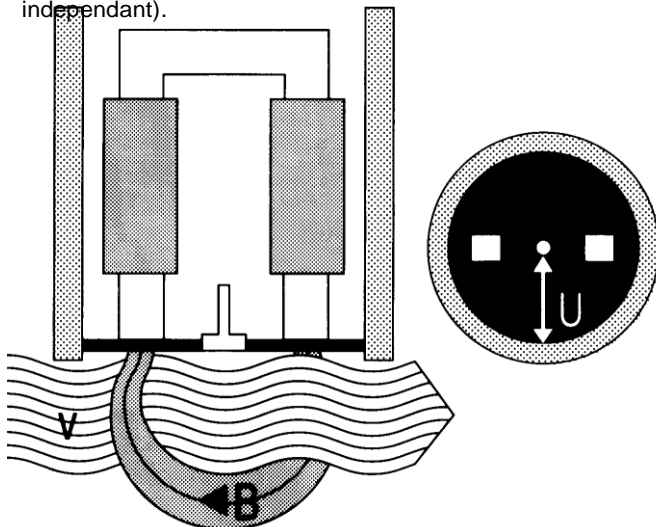

Components of DWM 1000/2000

- 1 Connection Socket
- 2 Gasket
- 3 Sensor
- 4 Threaded Connection (1")
- 5 Earthing Cable
- 6 Earth Clamping Strap
- 7 Cable Entry Gland M20x1.5
- 8 Housing
- 9 Blanking Plug
- 10 Supply Terminals
- 11 Connection Chamber
- 12 Magnetic Coils and Electrode Contacts
- 13 Electronic Unit
- 14 Cover Screws
- 15 Cover With Fitted Gasket

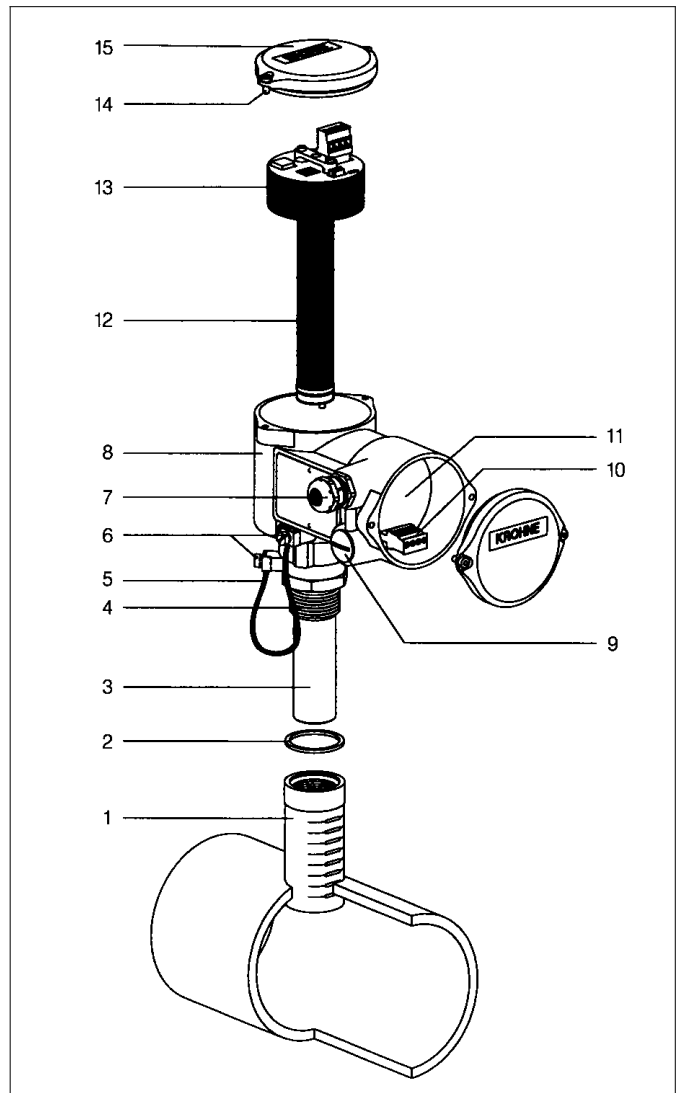

Installation

Mounting onto the pipeline

- The DWM should be mounted onto the pipeline (nominal diameter (DN) 50mm (2") by means of the connection socket provided.
- Refer to the diagrams below for the orientation and positioning of the connection socket. The socket should be inserted as far as the corresponding pipeline diameter (DN) marking. In case there is pipe insulation, it is necessary to calculate the depth of insertion so that the protrusion of the probe is 1/8 of the true internal diameter (i.e. not the DN).
- The location hole in the pipeline should be drilled to a diameter of 39 mm (1.54") with a maximum of 0.5 mm play between the socket and bore. Secure the socket perpendicular to the pipe with four spot welds, then carry out an unbroken weld of the entire diameter, with an electrode of 1.2mm diameter and setting of 90 to 150A.
- The straight line flow distance required between the DWM and an upstream flow disturbance (inlet, pump, elbow etc) is advised to be 10 x DN and 5 x DN from downstream disturbances.
- The DWM must be installed into the socket using the supplied gasket, which ensures water tightness and flush positioning of the ceramic probe head. Teflon tape should not be used on the thread as this insulates the required earthing contact, and prevents from correct protrusion of the probe.
- Only the electronics unit must be rotated according to the flow direction (see "Electrical Connection and Setting").

Installation on plastic pipes

In the case where the unit is to be installed on a plastic flow pipe, it is necessary to assure an earth connection. In all cases consult KROHNE to ensure an effective solution.

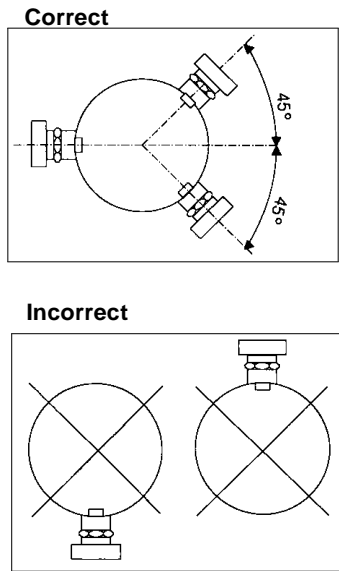
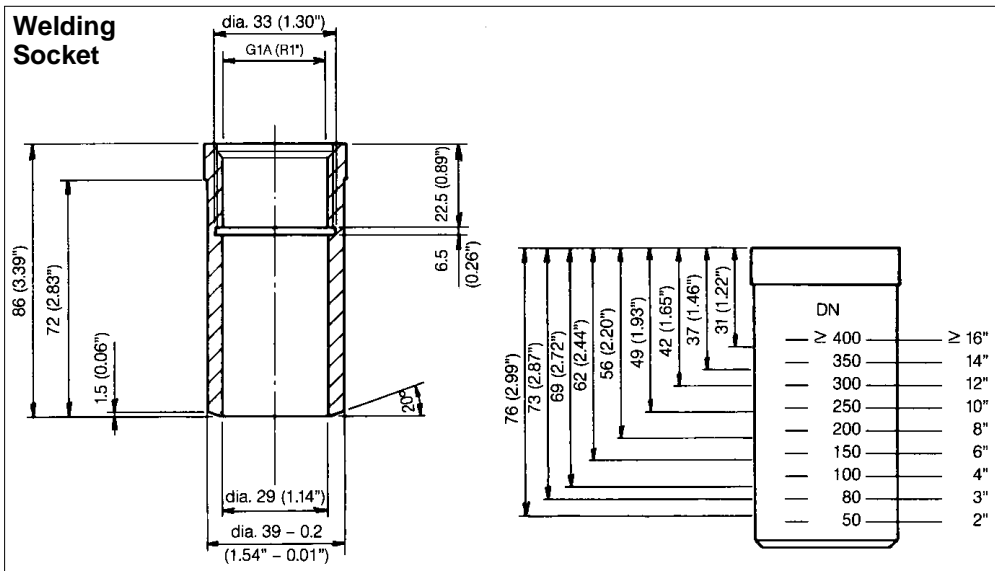

Dimensions and Weight

Diecast aluminium housing - weight excluding socket approx. 1.85Kg (4.08lbs)

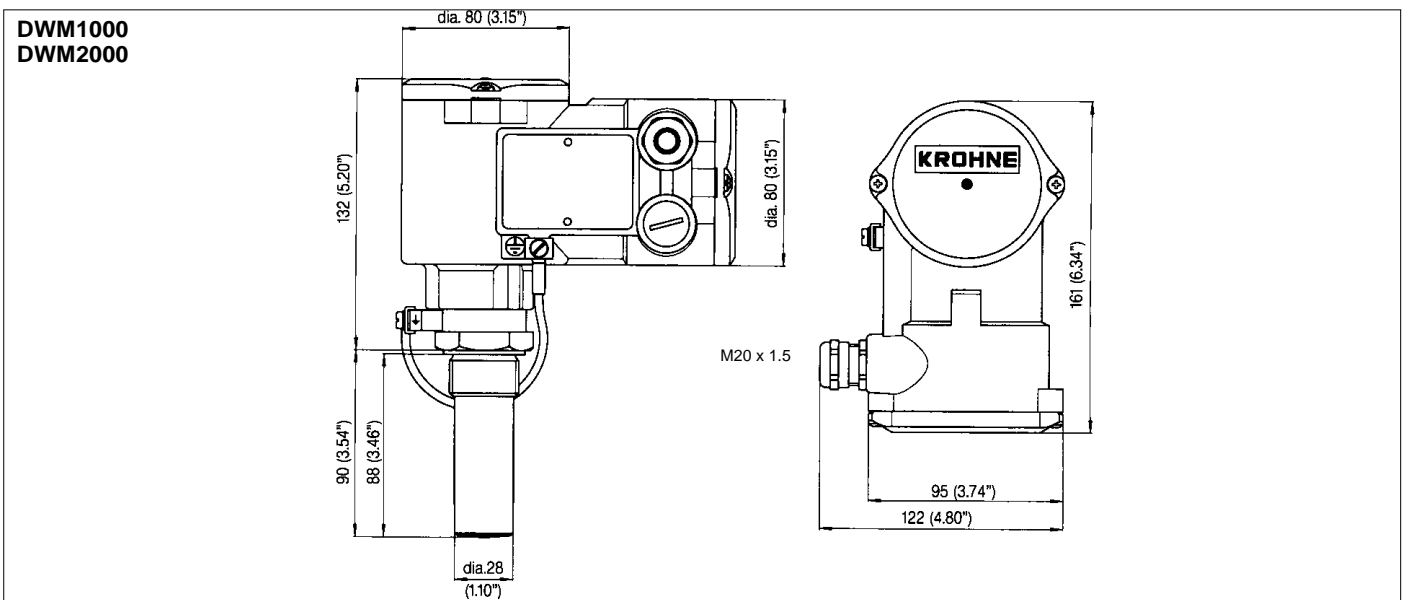

Electrical Connection and Settings

Electrical Connection

- n The wiring terminals for the DWM can be found in the connection chamber (see page 3, item 11).
- n The electrical connection conforms to the standard EN61010-1, protection class 1, voltage category II, interference degree 2.
- n The DWM range conforms to EMC directives NF EN 50 081.1 (Emission) and NF EN 50 082.2 (Immunity)
- n For DWM 1000 see "ERRATA DWM 1000 Flow Switch"

DWM1000 Flow Switch

- n Terminals 1 and 2 are used for the electrical connection (wire cross-section: max. 1.5mm² or 16 AWG). Polarity is arbitrary.
- n The flow switch must not be connected to power without an electrical load in series (e.g. relay)!
- n The choice for the alarm status NO (circuit open for velocity higher than reference velocity) or NC (circuit open for inverse function) can be changed by the switching as detailed on the right.
- n If more than one DWM1000 is used, make sure they are not connected in parallel. Only one common return is allowed. Provide a separate fuse for each flow switch.
- n Ensure that the earthing of the unit is <10 Ohms.

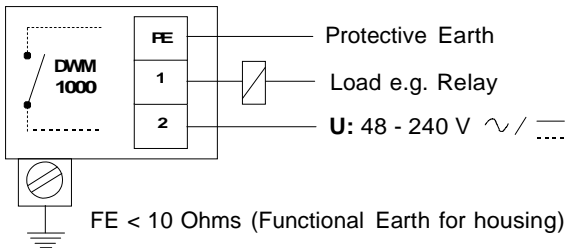

Relay Limits

- n Always ensure that the voltage and relay voltage correspond with compatibility specifications. Refer to the 'Compatible Relay' section for the choice of relay on page 7.

Settings

The settings have to be carried out in the following order:

- n Positioning of the electronic block.
- n Setting of reference velocity.
- n Setting of the time constant.
- n Setting of the alarm status: NO or NC.

Open the housing and unscrew the two mounting screws (14) of the electronic block (only two turns) without taking them out. Position the block aligning the arrow with the direction of flow in the pipe (if not aligned false readings will occur). The block is then fixed by fully tightening the mounting screws.

Setting of the Reference Velocity

Set the reference velocity with the two dials (11), one for the m/s units and the other for the 1/10ths units.

Setting of the Time Constant

Set the time constant with the dial (12) to 5, 8 or 10 seconds. Depending on the desired function of the unit, program the time constant to the largest possible, to avoid unnecessary switching during fluctuations in the flow rate.

Setting of the Alarm Status

The alarm status can be selected with the inverter (13).
 NO - circuit open for velocity higher than reference velocity.
 NC - circuit closed for velocity higher than reference velocity.
 The LED flashes when the circuit is open.

Make Contact Status (NO)

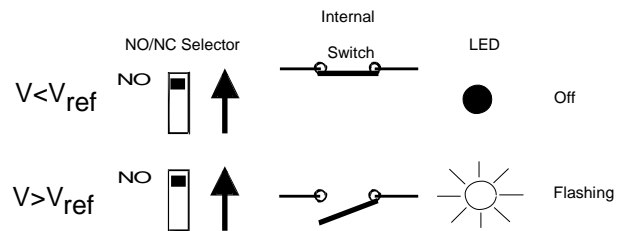

Break Contact Status (NC)

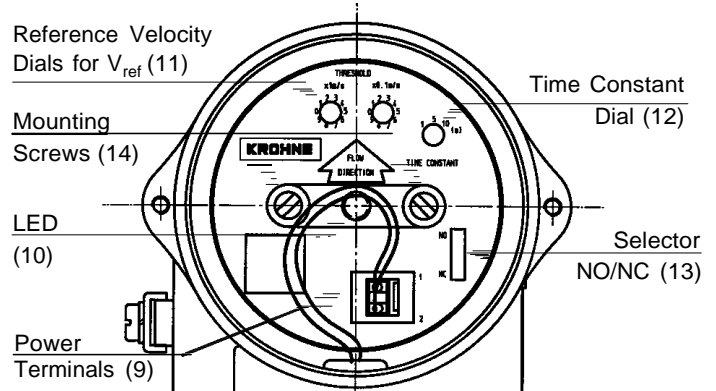
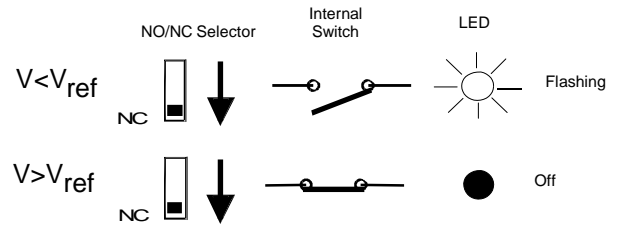

Installation on Piping With Cathodic Protection

Please contact KROHNE directly for instructions.

Removal and Remounting of the Electronic Block

The electronic block may be removed in security during flow conditions, as the probe is fully sealed. Before removing the unit ensure that the power supply is switched off. Unscrew the two mounting screws fully (14), and pull the block by means of the plastic bridge.

To replace the block, it should be orientated so that the screws (14) engage into the threads of the rotating sleeve, and secured in place with a few turns. Next orientate the block so that the arrow is in line with the flow direction, and lock the block by fully tightening the mounting screws.

Note - the replacement block needs to be calibrated.

Electrical Connection and Settings

DWM2000 Flowmeter (current output)

The connection and settings have to be carried out in the following order:

- n Positioning of the electronic block.
- n Setting of the full scale.
- n Electrical connection and earthing (must be <10 Ohms).
- n Zero adjustment.

Positioning of the electronic block

Open the housing and unscrew the two mounting screws (14) of the electronic block (only two turns) without taking them out. Position the block aligning the arrow with the direction of flow in the pipe (if not aligned false readings will occur). The block is then fixed by fully tightening the mounting screws.

Setting of the Full Scale

The setting of the full scale has to be done before powering up the DWM2000! Full scale range is from 1 through to 8m/s, and is set by means of the 1, 2, 4 and 8 value switches. The final value of the full scale is the sum of the switches activated. The switch has to be at the side of the inscription to be activated. If the full scale is set improperly (i.e. >8m/s), the device will be in alarm status (output current <3mA).

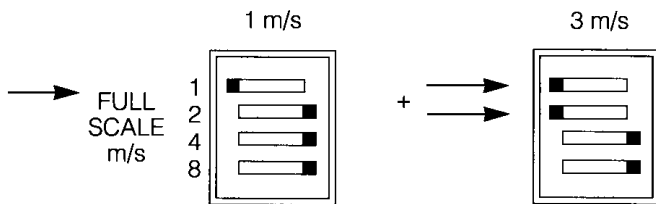

Connection

- n Power the unit with 24VDC (power terminals marked 11 (-) and 12 (+)). Maximum wire diameter is 1.5mm.
- n The power consumption at 24VDC is 50mA (max at 20°C)
- n Power the current output with 24VDC (power terminals 6 (-) and 5 (+)). Beware of polarity! Max. load is 500 Ohms.
- n One power supply can be used to supply the DWM2000 and current output (see diagram).
- n After powering the DWM2000 will do a self-test (1 minute), during which current output will be in alarm state (<3mA). If the self-test is OK the DWM2000 will start measuring, if not, the output will remain in alarm state (<3mA).

Zero Adjustment

Ensure that the pipe is full. There should be no flow velocity in the pipe. Press the "Zero" key. After 1 minute, the zero setting will be automatically adjusted. During zero calibration, the output indicates alarm status (<3mA).

Piping With Cathodic Protection

Please contact KROHNE directly for instructions.

Removal and Remounting of the Electronic Block

The following procedure must be carried out by a qualified technician:

The electronic block may be removed in security during flow conditions, as the probe is fully sealed. Before removing the unit ensure that the power supply is switched off. Unscrew the two mounting screws fully (14), and pull the block by means of the plastic bridge.

To replace the block, it should be orientated so that the screws (14) engage into the threads of the rotating sleeve, and secured in place with a few turns. Next orientate the block so that the arrow is in line with the flow direction, and lock the block by fully tightening the mounting screws.

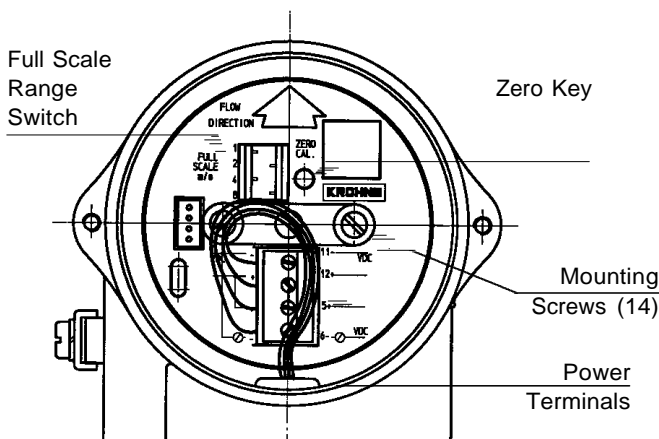

Electrical Wiring

Common Power Supply

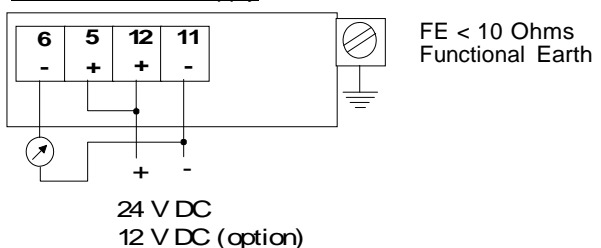

Separate Power Supplies

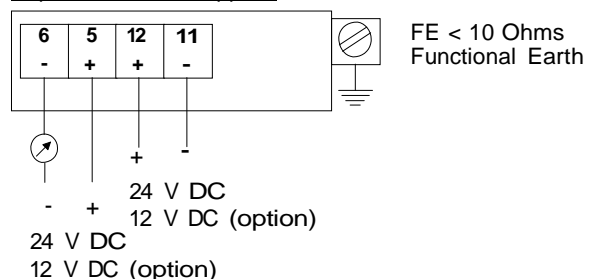

Reminder for Flow Volume Calculations:

$$V = 354 \frac{Q}{D^2}$$

V = m/s
 Q = m³/h
 D = internal pipe diameter in mm

Note: for Zone 2 applications, a fuse is required for the positive (+) output with a rating 200mA.

DWM 1000 Compatible Relays

This list includes those relays tested by KROHNE, and is not exhaustive.

Manufacturer	Reference	Power supply (tested range)
SCHNEIDER	LC1K0610M7	230 VAC (+/- 10%)
Klöckner MOELLER	DILR40	230 VAC (+/- 10%)
Klöckner MOELLER	DILR22	230 VAC (+/- 10%)
SCHNEIDER	CA3KN40GD	125 VDC (+/- 20%)

DWM 2000 IP68

The version IP68 is supplied as a sealed unit, with all calibration carried out before delivery. The customer has to be aware in particular that the cable packing gland must not be opened as it is specially sealed according to regulations.

Ensure to install the unit onto the flowpipe before connecting the cable, as the cable needs to be free during the rotation of the unit. The unit must be installed with the flow arrow marked on the top of the housing aligned with the flow in the pipe.

For the wiring of the versions IP68, see the two diagrams below, showing the two options of a common or separate power supplies. The numbering corresponds to the following wire colours: 11 - Brown; 12 - Red; 5 - Orange; 6 - Yellow

For all electrical information refer to DWM2000 Technical Data specifications on page 11.

The DWM 2000 IP68 can also be ordered with extended probe, as detailed below in the DWM 2000 L.

Wiring:

Common Power Supply

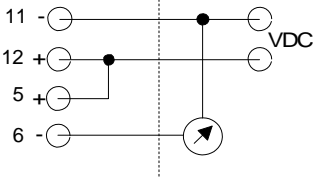

Separate Power Supply

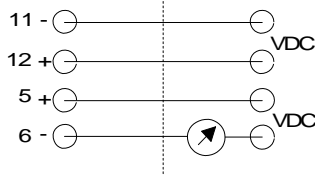

11 - brown; 12 - red; 5 - orange; 6 - yellow

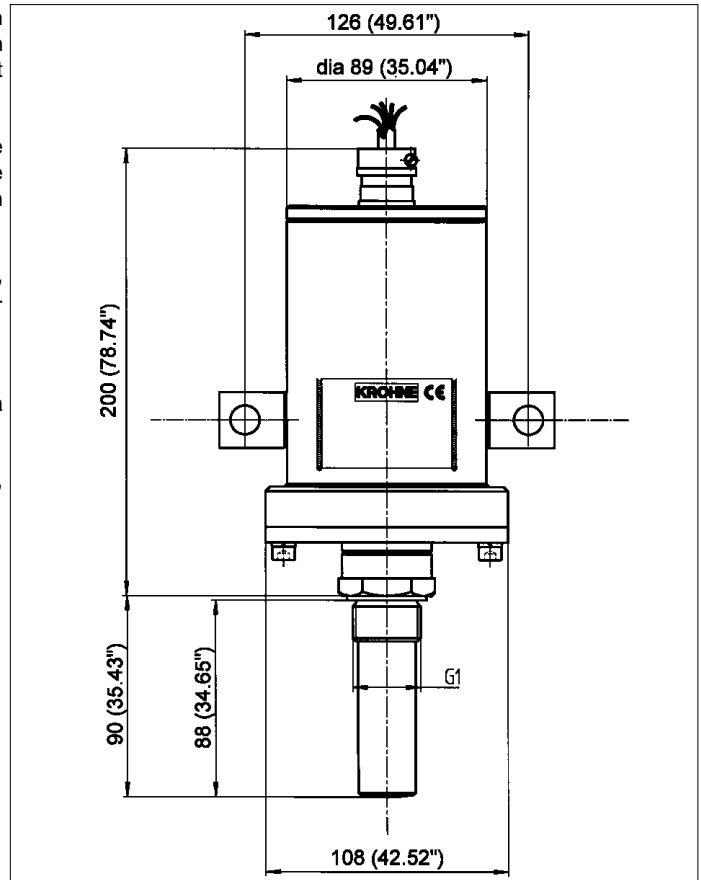

DWM 2000 L

Characteristics

Same characteristics as DWM2000 but adapted for the following special conditions:

- n Velocity measurement in open channel. Combined with ultrasonic level measurement gives flow volume measurement.
- n Flow control in pipes or open channels.
- n Spool piece mounting, T-mounting.
- n Option: Hot-tap mounting, equipped with isolation valve.
- n Option: adjustable high pressure screw connection with security chain for mounting and dismounting.
- n Can be used instead of insertion turbines, flow controllers.
- n Possibility to measure velocity at different points in open channels, rivers etc.
- n Probe lengths up to 3m possible.
- n Easy to transport in order to carry out field tests.
- n Protection class IP55.
- n Special option IP68 with submerged converter.

Max Product Temperature: 150°C (IP55), 60°C (IP68)

Max Operating Pressure: 25 bar

Ambient Temperature Range: -25°C to + 60°C

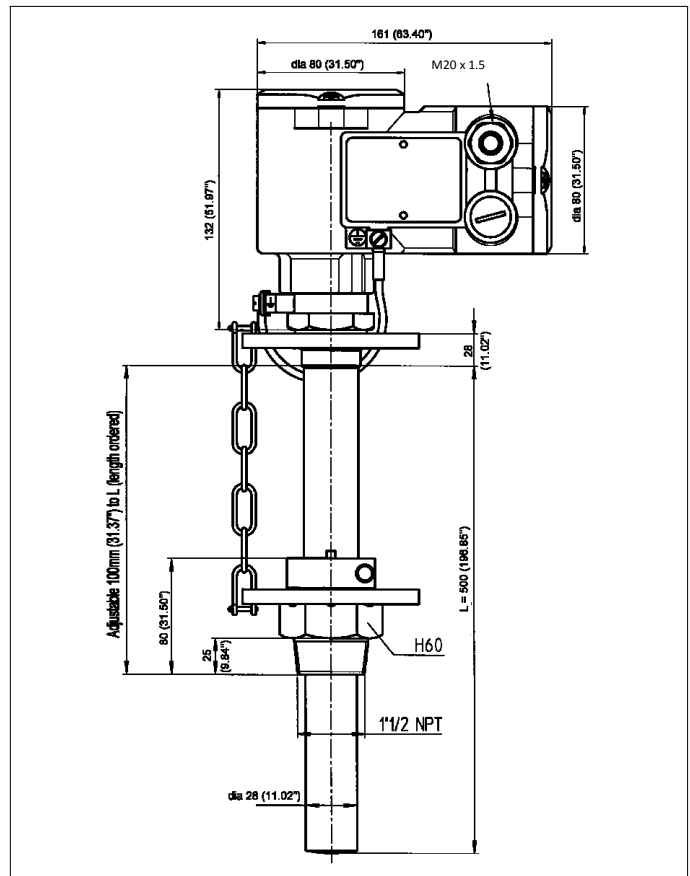

DWM 2000 L - Installation

A. Installation on Flow Pipes

- n The straight line flow distance required between the DWM and an upstream flow disturbance (inlet, pump, elbow etc) is advised to be 10 x DN and 5 x DN from downstream disturbances.
- n Position the pipe saddle or the welding socket as indicated in the installation sketch.
- n Screw the ball valve onto the welding socket (or connection flange according to the saddle design). The valve thread is 1"1/2.
- n Ensure that the ball valve is closed.
- n Screw the adjustable fitting onto the ball valve.
- n Slide the DMW2000/L into the adjustable fitting to a depth of between 60 et 75mm. This assures that the mounting will be watertight.
- n The security chain is supplied to the required length as determined for each application. This length cannot be extended, but may be shortened where necessary.
- n Loosen screw (No. 2 in sketch below) slightly. This enables the DWM2000/L to be inserted further without any leakage.
- n Open the ball valve.
- n Calculate the penetration length (= 1/8 DN Nominal Diameter) with a tolerance of +2mm - 0mm.
- n If flow is heavily perturbed or the internal diameter is uncertain, it is advised to penetrate between 1/8 DN and 1/2 DN.
- n Insert the DWM2000/L until measurement position is reached.
- n Take off the housing cover and turn the entire probe so that the arrow points in flow direction (this system differs from standard DWM 1000/2000).
- n Tighten alternatively the two screws (No.3 in sketch) up to max 3N/m, to seal off the fluid. Complete the installation by tightening screw (No.2).

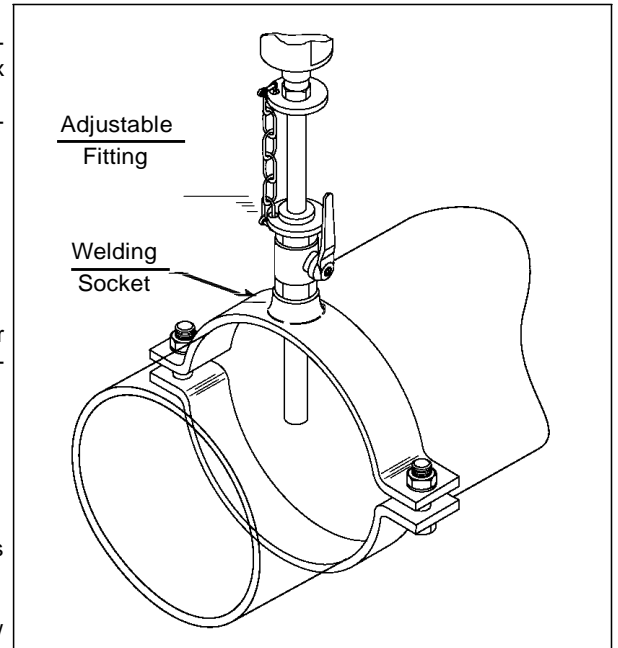

Installation on pipe saddle

Preferred mounting angle: horizontal $\pm 45^\circ$

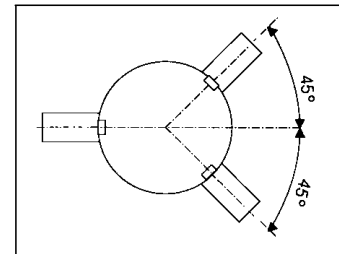

Installation with welding socket

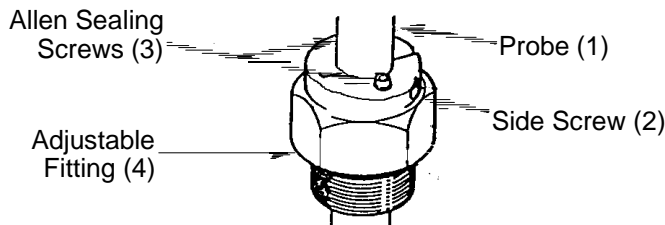

max. pressure 25 bar

B. Installation on Open Channels

- n The DWM2000/L can be mounted by using the adjustable fitting.
- n Position the device in such a way that the arrow points in the flow direction.

Remarks

- n The electronics block of this long version is interchangeable.
- n **For safety reasons, keep the security chain mounted, in order to avoid any ejection in case of overpressure in the pipe.**
- n For range settings and electrical connection, refer to DWM2000 standard version instructions.

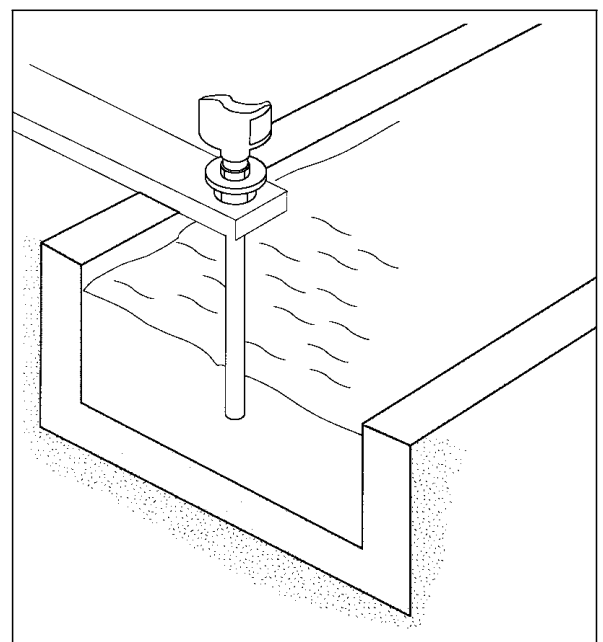

Installation in an open channel

Trouble Shooting

Below is a list of possible problems, and the checks required for their resolution. In all cases ensure that the installation instructions have been followed e.g. supply voltage, relay compatibility (DWM1000 only), earthing (<10 Ohms), straight line flow distances, and flow in pipe is full.

DWM 1000

Fault: The relay does not switch according to reference velocity.

Checks

When the selector is inverted, does the relay switch?

Advance the reference velocity from 0 m/s through to 9m/s - does the relay switch?

Action

If no, measure the consumption of the unit whilst the LED is illuminated. If $i < 5.5\text{mA}$ for DC (12 mA for AC), insert a resistor in parallel with the relay coils of ratings 1, 3 or 10kOhms (5W) corresponding to voltages 48, 110, and 230V respectively.

If no, and the LED changed state, replace the electronics unit. If yes, note the reference velocity value, and check this against the real velocity.

Fault: The relay switches randomly.

Checks

Liquid heavily charged with particles? Flow speed close to 0.1m/s? Straight line flow distances too short? Air bubbles in liquid (at high temperatures)?

Action

Increase the time constant to 10s. If results are the same, increase the reference velocity. If the results remain the same, insert a resistor in parallel with the relay coils of ratings 1, 3 or 10kOhms (5W) corresponding to voltages 48, 110, and 230V respectively.

DWM 2000

Fault: The output current is fixed at 0mA.

Checks

Output signal correctly powered?
Polarity correct on supply connections?
Liquid inside the probe body?

Action

Refer to Technical Data specifications.
Refer to wiring diagrams.
Contact KROHNE Service Department.

Fault: The pipe flow is higher than 0.1m/s and the output current remains at 4mA (+/- 0.02mA).

Checks

Orientation of the electronic unit correct?

Action

Loosen the fixing screws, and align the arrow with the pipe flow

Fault: The output current is fixed at below 3mA.

Checks

Power supply stable? (nominally +/-1%)
Current at 2.0mA?
Current at 2.4mA?

Action

Change power supply.
Reset the Full Scale switches to between 1 and 8m/s.
Zero setting too large - reset the zero with the pipe full and $v=0$ m/s.

For all other alarm output readings, contact KROHNE.

Fault: There is no flow in the pipe, and the output current is instable (4mA +/-1mA).

Checks

Is the output current stable when tested by a multi-meter?
Is the earth <10 Ohms?

Action

If no, trace and eliminate the interference source.

Establish a correct earthing point.

Fault: The output current is above 4mA, but the reading is incorrect.

Checks

Reading above 24mA?
Fluctuations, but average reading correct?
Installation correct?

Action

Ensure conformity to power supply specifications.
Increase the time constant value using the HHC2000 console.
Verify mounting specifications (probe penetration in pipe, right-angles, orientation of electronic unit).

Pipe not full?
Speed/flow calculations correct?
Is the output current correctly calibrated?

Ensure that the pipe is full during flow conditions.
Check the internal diameter of the pipe and reset the Full Scale.
Test the output current with the HHC2000 console.

DWM Technical Data

	DWM 1000 Flow Switch Two Wire System	DWM 2000 Flow Meter Output Current 4 - 20 mA
Power Supply and Output		
Voltage	48-240 \sim , 50/60 Hz or 48V $\overline{\text{---}}$ (Terminals 1/2)	24 $\overline{\text{---}}$ (20 to 30 $\overline{\text{---}}$) Option: 12 $\overline{\text{---}}$ (10 to 14 $\overline{\text{---}}$) 50 mA max. (at 24 $\overline{\text{---}}$ and 20°C)
Power Consumption	200mA max.	Passive current output 4 - 20 mA (20 to 30 $\overline{\text{---}}$)
Output	Break or make contact, switch selected (for relay contact limits see 'Electrical Connection').	Max. load: 500 Ohms for 24 $\overline{\text{---}}$ 200 Ohms for 12 $\overline{\text{---}}$
Functional Earth FE (Protective)	<10 Ohms Protective earthing obligatory in connection chamber	<10 Ohms
Full-Scale Range "v" Adjustable	Reference velocity between 0.1 and 9.9 m/s (0.3 and 32.5 ft/s)	Full scale 1, 2, 3, 4, 5, 6, 7 or 8 m/s (3.3, 6.6, 9.9, 13.1, 16.4, 19.6, 22.9 or 26.2 ft/s)
Time Constant	choice of 5, 8 or 10 seconds	5 seconds fixed
Operating Data	Largely homogeneous liquids, pastes and slurries, also with solids content	
Liquid	$\geq 20 \mu\text{s/cm}$ ($\mu\text{mho/cm}$)	
Electrical Conductivity	25 bar (360 psi)	
Operating Pressure	- 25 to + 150° C (-13 to +302°F)	
Process Temperature	- 25 to + 60° C (-13 to +140°F)	
Ambient Temperature		
Installation	All DN's ≥ 50 mm (2")	
Nominal Pipe Diameter (DN)	Threaded G1A (R 1")	
Connection Socket	10 x DN / 5 x DN	
Inlet / Outlet Run		
Protection Category	IP 55, Equivalent to NEMA 4 IP55 or IP68	
Local Display	Flashing LED (DWM 1000 only)	
Cable Entry	M20 x 1.5	
Power Terminals	Max. wire diameter 1,5 mm ² (16 AWG)	
Error Limits	SP = Switching Point	MV = Measured Value
v > 1 m/s (3.3 ft/s)	5% of SP	2% of MV
v < 1 m/s (3.3 ft/s)	3 cm/s (1.2 inches/s) + 2% of SP	2 cm/s (0.79 inches/s)
Reproducibility	1% of Switching Point	+/- 1.5% of MV
Hysteresis	8% when decreasing velocity	8% when decreasing velocity
Interchangeability	In the case of a breakdown we advise a complete replacement of the DWM unit in order to preserve the accuracy of the results. A change in the electronic threshold can induce errors of <10%	
Ex Versions Coding (on side label)		Ex n R II T6...T3 X Zone 2 (according to IEC 79-15)
Materials:	CrNi - Stainless Steel 1.4435 (SS 316 L - AISI) + ceramic insulation (zirconium oxide)	
<u>Probe</u>	Platinum	
<u>Electrode</u>	Diecast aluminium with epoxy finish	
<u>Housing</u>	Stainless Steel 1.4435 (SS 316 L - AISI)	
<u>Connection Socket</u>	Nickel plated brass	
<u>Cable Entry Gland</u>		
<u>Gaskets</u>	Buna N	
<u>Housing Cover</u>	Viton	
<u>Ceramic Seal</u>	Klingerit (without asbestos)	
<u>Connection Socket</u>		



Krohne S.A.
2, Allée des Ors - B.P. 98
26103 ROMANS Cedex
Tél. : +33 (0)4 75 05 44 00
Télex : 345 153
Télécopie : +33 (0)4 75 05 00 48

R.C. Romans 63 B 13
Sous réserve de modifications pour raisons techniques. Printed in France

© Copyright Krohne S.A. ROMANS

Austria

Krohne Ges.m.b.H.
Wagramerstrasse 81
Donauzentrum
A-1220 Wien
Tel. (01) 2 03 45 32
2 03 23 28
Telex : 115 864
Fax : (01) 2 03 47 78

Germany

Krohne Meßtechnik
GmbH & Co.KG
Postfach 10 08 62
D-47008 Duisburg
Ludwig-Krohne-Strasse 5
D-47058 Duisburg
Tel. (0203) 301-0
Telex : 17 203 301
Fax : (02 03) 301 389

Netherlands

Krohne Persenaire
Kerkeplaat 12
3313 LC Dordrecht
oder
Postbus 110
3300 AC Dordrecht
Telefon : (078) 630 6200
Telefax : (078) 630 6234

Belgium

Krohne Belgium N.V.
Brusselstraat 320
B - 1702 Groot Bijgaarden
Tel. (02) 4 66 00 10
Fax : (02) 4 66 08 00

Great-Britain

Krohne Measurement & Control Ltd.
Rutherford Drive
Park Farm Industrial Estate
Wellingborough, Northants NN8 6AE
Tel. (0 19 33) 40 85 00
Fax : (0 19 33) 40 85 01

South Africa

Krohne (Pty) Ltd
P.O. Box 2078
1685 Halfway House
557 15th Road
Midrand
Tel. (0 11) 3 14 13 51
Fax : (0 11) 3 14 11 37

Representations

Algeria
Argentina
Australia
Brazil
Bulgaria
Cameroon
Canada
Chile
Czech Republic
Denmark
Ecuador
Egypt
Finland
Greece
Hungaria
Indonesia
Iran
Ireland
Israël
Ivory Coast
Jordan
Kuwait
Malaysia
Mauritius
Mexico
Morocco
Nigeria
Norway
Oman
Pakistan
Poland
Portugal
Quatar
Saudi Arabia
Senegal
Singapore
Sweden
Taiwan
Thailand
The Philippines
Tunisia
Turkey
U.A.E.
Venezuela

China

Kanex Krohne Beijing
Rm 830, Old Bldg, Xiyuan Hotel
Xi Jiao Er Li Gou Beijing, P.R. of China
Tel. 00 86-(0) 10-8313388 Ex 5830
Telex : 22 831 XYHCN Ex 5830
Fax : 00 86-(0) 10-68310661

Hong Kong

Kanex Krohne Hong Kong Co.
Room 112, Tung Shun King Office
Center, 1st floor
N° 22 Chi Kiang Street
Tokwawan, Kowloon, Hong Kong
Tel. (852) 233 397 88
or 236 301 11
Fax : (852) 277 437 26

Spain

Instrumentacion Industrial
Krohne Iberia, S.r.l.
Poligono Industrial Alcala I
Calle El Escorial, nave 206
E-28805 Alcala de Henares
Madrid
Tel. (9) 18 83 21 52
Fax : (9) 18 83 48 54

China

Kanex Krohne Shanghai
Room 928B, Jin Du Mansion
277 Wu Xing Road
Shanghai 200 233, P.R. of China
Tel. 0086-(0) 21-64674949
or 64675353
Fax : 0086-(0) 21-64673399
Cellphone : 0086-(0) 139 1721320

India

Krohne Marschall Pvt. Ltd
A-34/35, MIDC
Industrial Estate
"H"-Block, Pimpri
Poona 411018
Tel. (02 12) 77 74 72
Telex : 0146-323 FSON
0146-221 JNMS
Fax : (02 12) 77 70 49

Switzerland

Krohne AG
Uferstrasse 90
Postfach 568
CH-4019 Basel
Tel. (0 61) 6 31 11 22
Telex : 963 452
Fax : (0 61) 6 31 14 18

CIS + Baltic States

Kanex Krohne Engineering AG
Malay Bronnay, 26/3
103001 Moscow / Russia
Post Box 23
177071 Moscow / Russia
Tel. 007-095-203 0095
ou 203 0249
Fax : 007-095-299 8219

Italy

Krohne Italia Srl
Via V. Monti 75
I-20145 Milano
Tel. (02) 43 00 661
Fax : (02) 43 00 6666

USA

Krohne America Inc.
7 Dearborn Road
Peabody, MA 01960
Tél. (508) 535 60 60
(1.800.356.9464)
Téléfax : (508) 535 17 20
PC Téléfax : (508) 535 3851
Internet address : krohne shore.net

France

KROHNE S.A.
Usine des Ors - B.P. 98
26103 Romans Cedex
Tel. 33-04.75.05.44.00
Telex 345 153
Fax. 33-04.75.05.00.48

Japan

Krohne Liaison Office
497-17 Kawakami
Totsuka
Yokohama 244
Tel. 81-45-8-26 30 34
Fax : 81-45-8-26 57 35

Electromagnetic Flow Switch DWM 1000 ERRATA

**INFORMATION!**

The data given on this errata sheet is applicable to DWM 1000 only.

Installation and Operating Instructions

For additional safety instructions about DWM 1000 devices, refer to [page 5](#)

Use one safety device per fuse ($I_n = 100\text{mA}$) in the power supply circuit. Use a switchgear device (switch, circuit-breaker) to disconnect the signal converter adjacent to the device. Switchgear must fully isolate the device (disconnect the 2 power lines), agree with the IEC 60947-1 and IEC 60947-3 standards and be identified as switchgear for this device.

Make sure that the electrical cable diameter is between 8 and 12 mm. Make sure that the cable gland holds the cable tightly. Electrical cables must have a temperature rating that agrees with the operating conditions.

Use a damp cloth to clean the device. Do not use aggressive or corrosive cleaning agents.

**DANGER!**

- *Do not open the device when it is energized. There is a risk of injury or death from dangerous voltages if you touch internal components after the device is connected to power supply. Do not operate the device without its cover.*
- *De-energize the device and disconnect the power supply before you do work on the electrical connections. Refer to the voltage data on the nameplate!*
- *The device must be grounded in accordance with regulations in order to protect personnel against electric shocks.*
- *Obey the national regulations for electrical installations!*

**WARNING!**

- *Risk of injury (burns) to personnel who touch the device, depending on the environmental and operating conditions.*
- *Obey fully the local occupational health and safety regulations. Only approved personnel can do work on electrical components of the measuring device.*