

## Installation and Setting-Up Instructions Spare Parts List



### Contents:

#### 1 INSTALLATION

- 1.1 Mechanical installation
  - 1.1.1 Installing welded process couplings
  - 1.1.2 Mounting the analyzer on the coupling
  - 1.1.3 Instructions and spare parts that are according and within the 3-A appliance.
  - 1.1.4 Spare parts and couplings
  - 1.1.5 Dimensions
- 1.2 Electrical connections

#### 2 SETTING UP

- 2.1 Setting up with Satron-VoAdvisor Service Software
- 2.2 Setting up with local switches
- 2.3 Setting up with VO remote unit

#### 3 USER GUIDE FOR MENUS

- 3.1 Measurement values menu
- 3.2 Menu structure

#### 4 DISPLAY SETUP

- 4.1 Setting up with "BASIC"
- 4.2 Setting up with "FULL"

#### 5 CALIBRATION

- 5.1 Calibration examples

#### 6 TECHNICAL DATA

### DOCUMENTS

Technical Specifications: BA200

Installation and Setting-Up Instructions: BA200AV

We reserve the right for technical modifications without prior notice.  
HART® is a registered trademark of HART Communication Foundation.  
Pasve™ is a trademark of Satron Instruments Inc.  
Hastelloy® is the registered trademark of Haynes International.  
Viton® is the registered trademark of DuPont Down Elastomers.



**Satron Instruments Inc.**

P.O.Box 22, FIN-33901 Tampere, Finland  
Tel.int. +358 207 464 800, Telefax +358 207 464 801  
www.satron.com, info@satron.com

# 1. INSTALLATION

## 1.1 Mechanical installation

**Mounting recommendations:** Fig. 1-1

- Process connection direction: horizontal
- Cable entry direction: from below
- Connector coupling direction, calibration direction: horizontal
- Process flow: Upwards

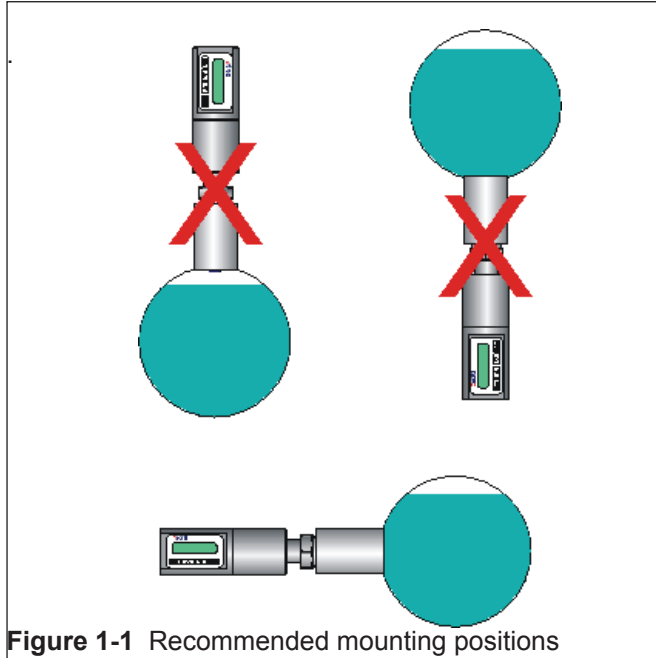

**Figure 1-1** Recommended mounting positions

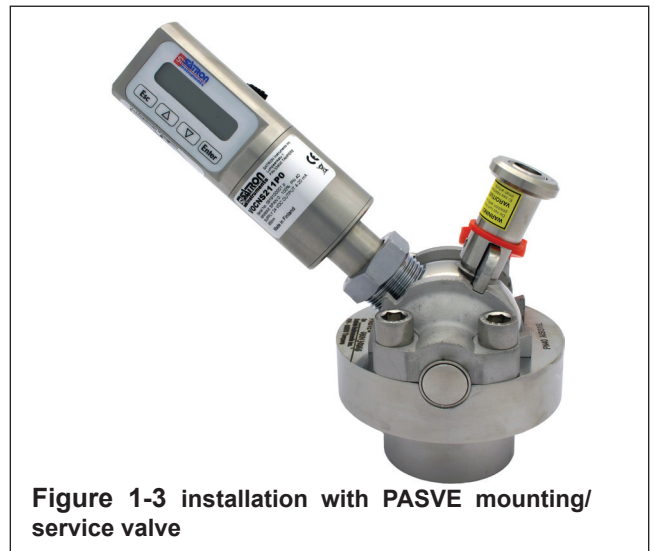

**Figure 1-3** installation with PASVE mounting/service valve

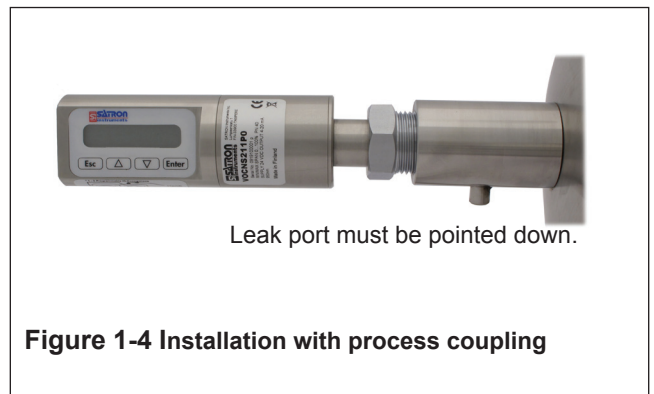

**Figure 1-4** Installation with process coupling

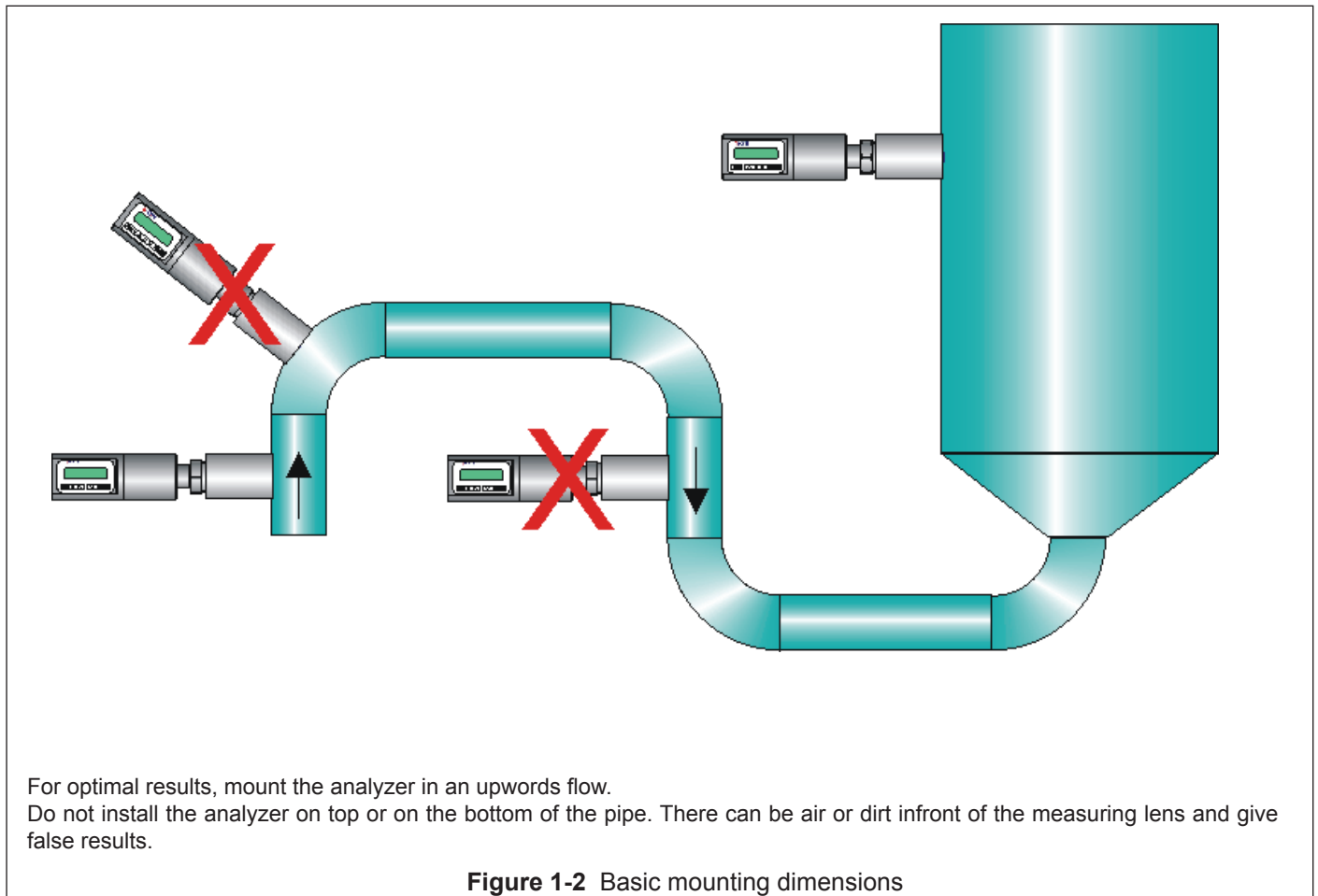

For optimal results, mount the analyzer in an upwinds flow.  
 Do not install the analyzer on top or on the bottom of the pipe. There can be air or dirt in front of the measuring lens and give false results.

**Figure 1-2** Basic mounting dimensions

**1.1.1 Installing welded process couplings.**

For  installations please goto page 4.

**Mounting hole for coupling**

- Make a  $\varnothing 45.5$  mm (+0.5/-0.2 mm) hole in the tank wall or pipe, as shown in Figure 1-5.

**Welding the coupling**

These instructions apply to all welded couplings; welding the G1 standard coupling is described here as an example.

- Place the coupling in the mounting hole as shown in Fig. 1-6. Then weld with several runs so as to prevent the coupling's oval distortion and tightness problems.
- The analyzer must be **out of the coupling** while the coupling is welded. You can use the shut-off plug shown in Fig. 1-7 to shut the coupling. The plug protects the coupling's sealing face and permits the starting of the process without the transmitter.
- It is always recommendable to use the welding assistant (M1050450) while welding the coupling to prevent any distortions due to heat.
- Do not make weld grounding via any analyzer's body!

**1.1.2 Mounting the analyzer on the coupling**

**Procedure**

- Make sure that the coupling's sealing face is clean.
- Remove the orange protective plug from the analyzer head.
- Insert the analyzer **in a straight line** (Fig. 1-8) into the coupling, so that the guide groove on the transmitter aligns with the stop pin on the coupling. The analyzer settles into position when the groove and pin are aligned, and will be prevented from rotating in the coupling.

**When inserting the analyzer, be careful not to damage the edge of the lens on the edges of the coupling or on the end of the stop pin!**

- Lock the transmitter in position by screwing the hex nut fully home. Finger tightness is sufficient to tighten the sealing faces. However, we recommend final tightening with a tool to eliminate the effect of vibration and other such factors. Apply  $60 \pm 20$  Nm torque.

**Do not use sealing tape etc. on threaded connection!**

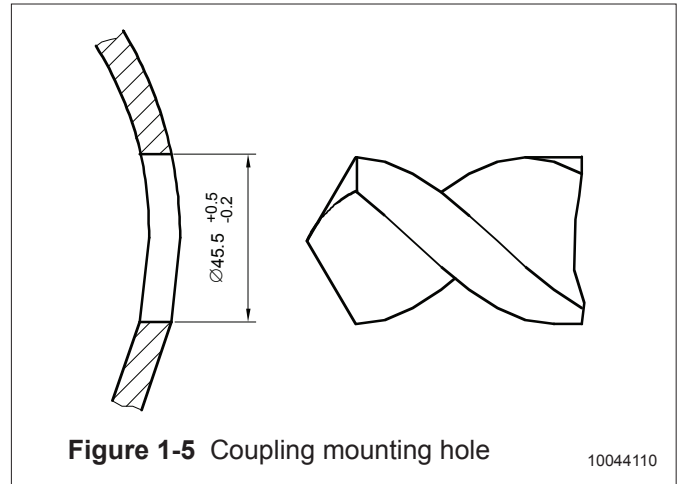

**Figure 1-5** Coupling mounting hole

10044110

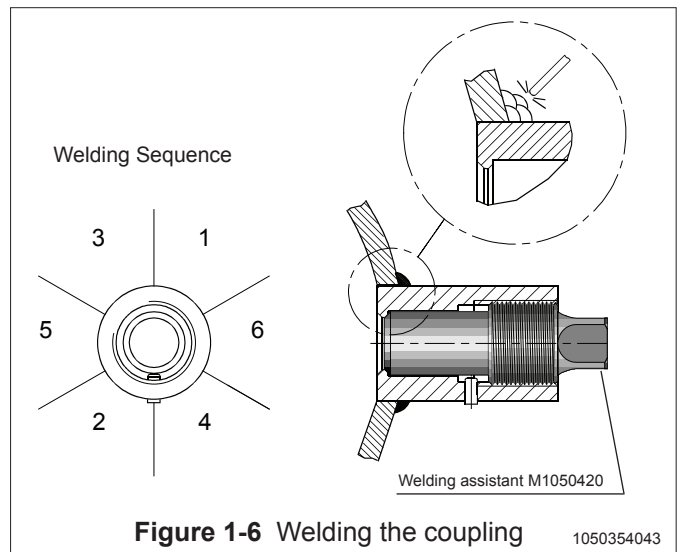

**Figure 1-6** Welding the coupling

1050354043

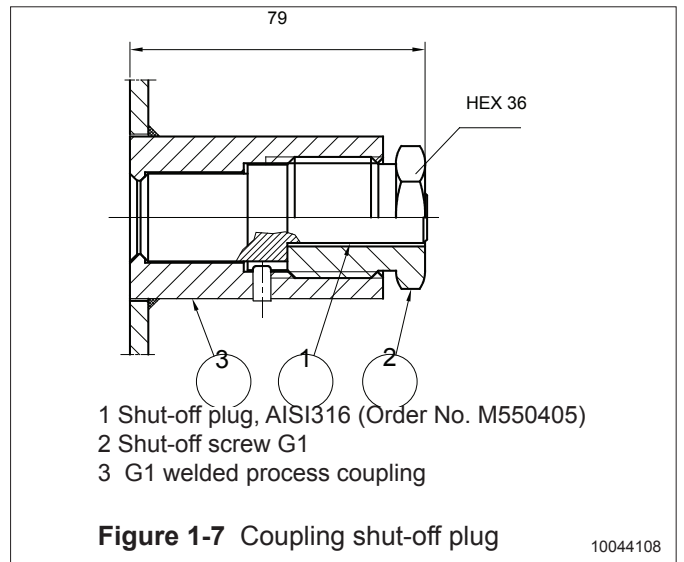

**Figure 1-7** Coupling shut-off plug

10044108

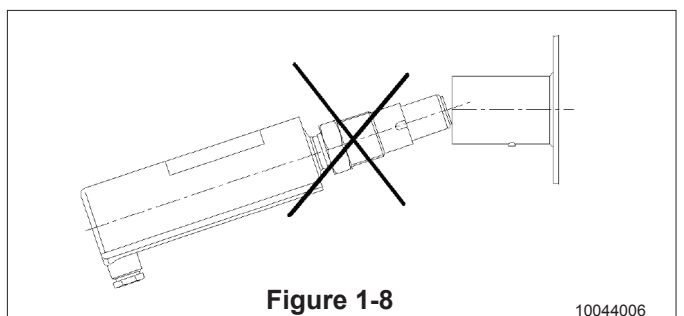

**Figure 1-8**

10044006

### 1.1.3 Instructions and spare parts that are according and within the 3-A appliance



#### Welding the coupling

All couplings that are according the 3-A appliance listed in the bottom of this page.

These instructions apply to hygienic welded couplings; welding the G1 M548101A coupling is described here as an example.

- Place the coupling in the mounting hole as shown in Fig. 1-7. Make sure the leakage detection port is down. Then weld with several runs so to prevent the coupling's oval distortion and tightness problems. The inside welding must be cleaned, and polished with an end result of Ra <0,8
- The analyzer must be **out of the coupling** while the coupling is welded. You can use the shut-off plug shown in to shut the coupling.

The plug protects the coupling's sealing face and permits the starting of the process without the transmitter.

- It is always recommendable to use the welding assistant (M1050450) while welding the coupling to prevent any distortions due to heat.

- Do not make weld grounding via any analyzer's body!

#### Mounting the analyzer on the coupling

##### Procedure

- Make sure that the coupling's sealing face is clean.
- Remove the orange protective plug from the analyzer head.
- Insert the analyzer **in a straight line** (Fig. 1-6) into the coupling, so that the guide groove on the transmitter aligns with the stop pin on the coupling. The analyzer settles into position when the groove and pin are aligned, and will be prevented from rotating in the coupling.

**When inserting the analyzer, be careful not to damage the edge of the lens on the edges of the coupling or on the end of the stop pin!**

- Lock the transmitter in position by screwing the hex nut fully home. Finger tightness is sufficient to tighten the sealing faces. However, we recommend final tightening with a tool to eliminate the effect of vibration and other such factors. Apply 60±20 Nm torque.

**Do not use sealing tape etc. on threaded connection!**

#### Spare parts

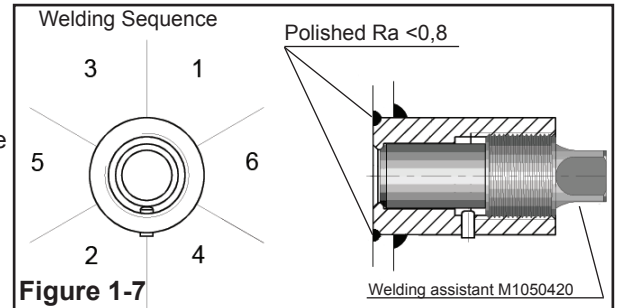
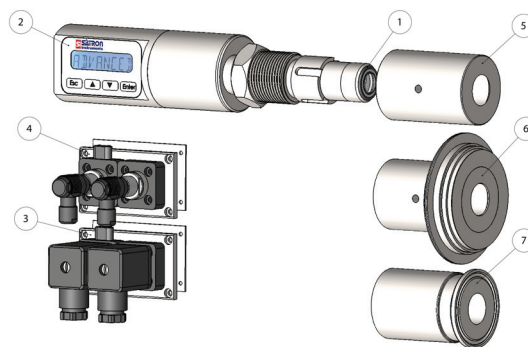

No.	Part name			
1	O-ring EPDM	80031720	3A 18-03 Class II	(Do not exceed above 8% fat content).
1	O-ring FPM (Viton®)	80011720	3A 18-03 Class I	
2	Sticker	T1325215		
3	Plug cover DIN43650	T1325003		
4	Plug cover M12	T1325005		
5	38/G1" Welding adapter	M1050577A		
5	45/G1" Welding adapter	M548101A		
6	Tuchenhagen / Varivent DN25	M1050090A		
6	Tuchenhagen / Varivent DN50	M1050091A		
6	Tuchenhagen / Varivent DN65,5	M1050092A		
7	Tri-clover 25/38 ISO2852	M1050206A		
7	Tri-clover 40/51 ISO2852	M1050222A		
7	Tri-clover 63.5 ISO2852	M1050224A		

1.1.4 Spare parts and couplings

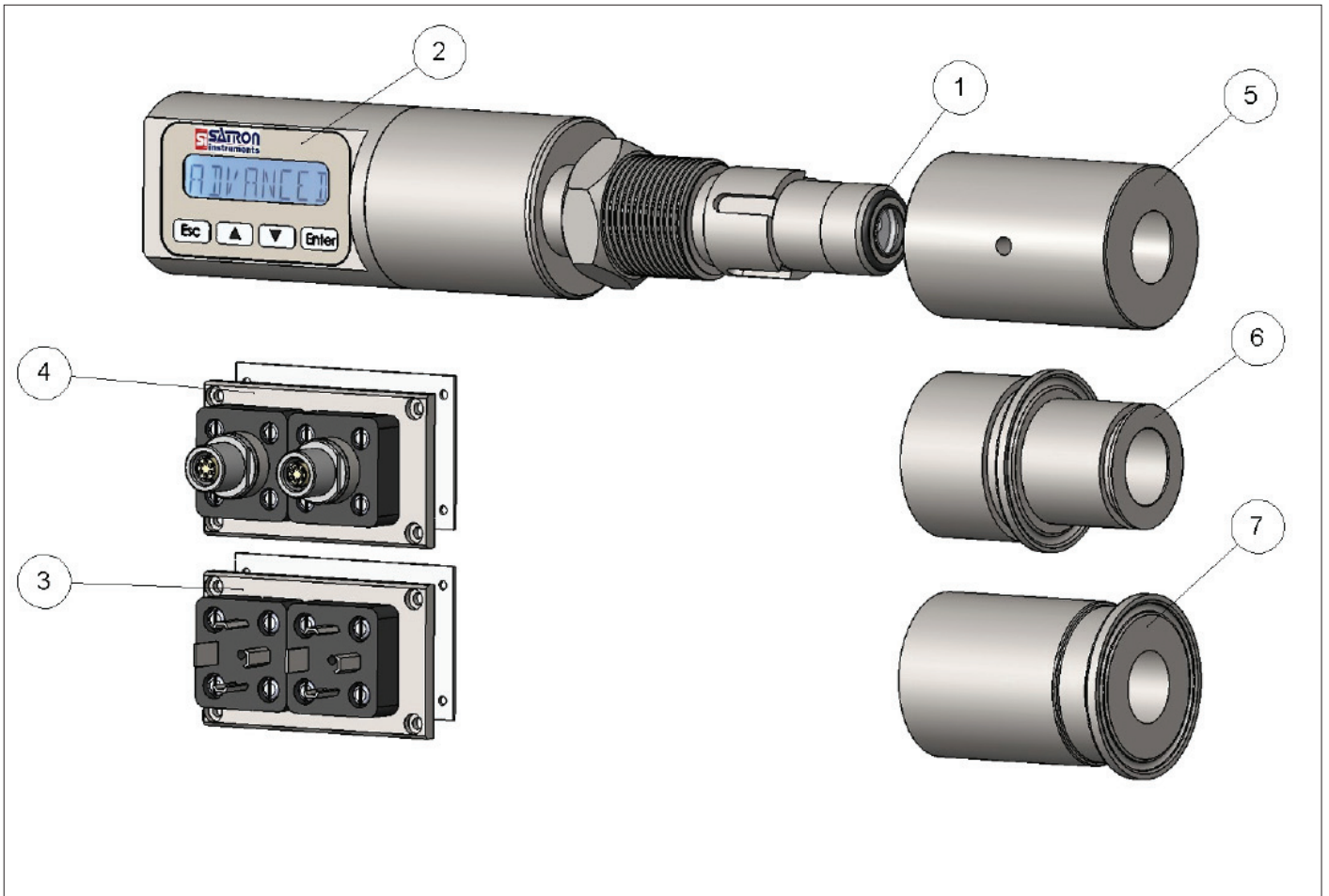

Part Number	Part name	Satron Order Number
1	O-ring (EPDM)	80031720
1	O-ring (FPM)	80011720
2	Sticker	T1325215
3	Plug connector DIN43650	T1325003
4	M12 connector	T1325005
5	Hygienic coupling	M548101
6	Tri-clamp 38	M1325229
7	Tri-clamp 38 ISO2852	M1050206
7	Tri-clamp 40 ISO2852	M1050222
7	Tri-clamp 51 ISO2852	M1050223
7	Tri-clamp 63.5 ISO2852	M1050224
Contact Satron Instruments for more couplings and adapters.		

### 1.1.5 Dimensions and Housing types VOM

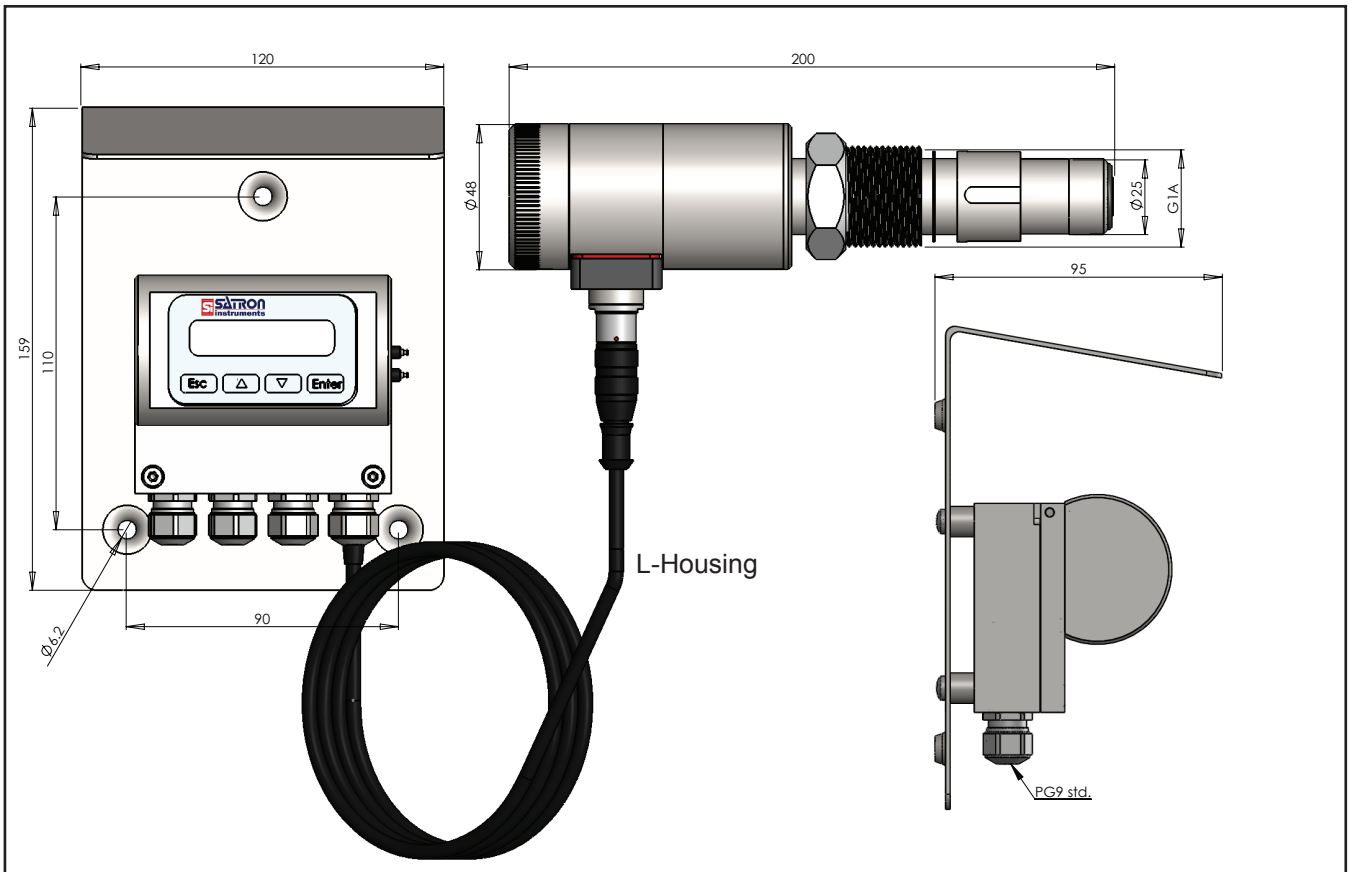
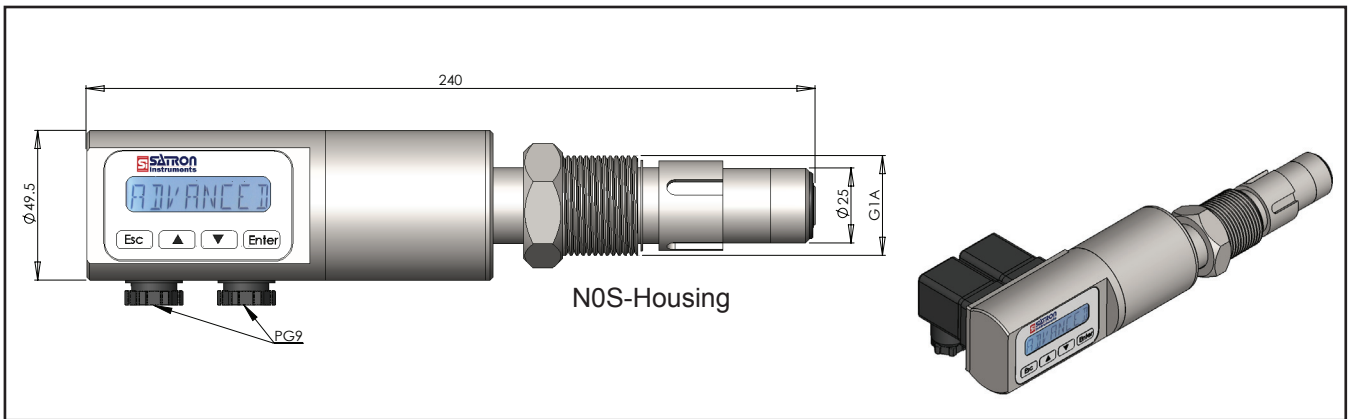
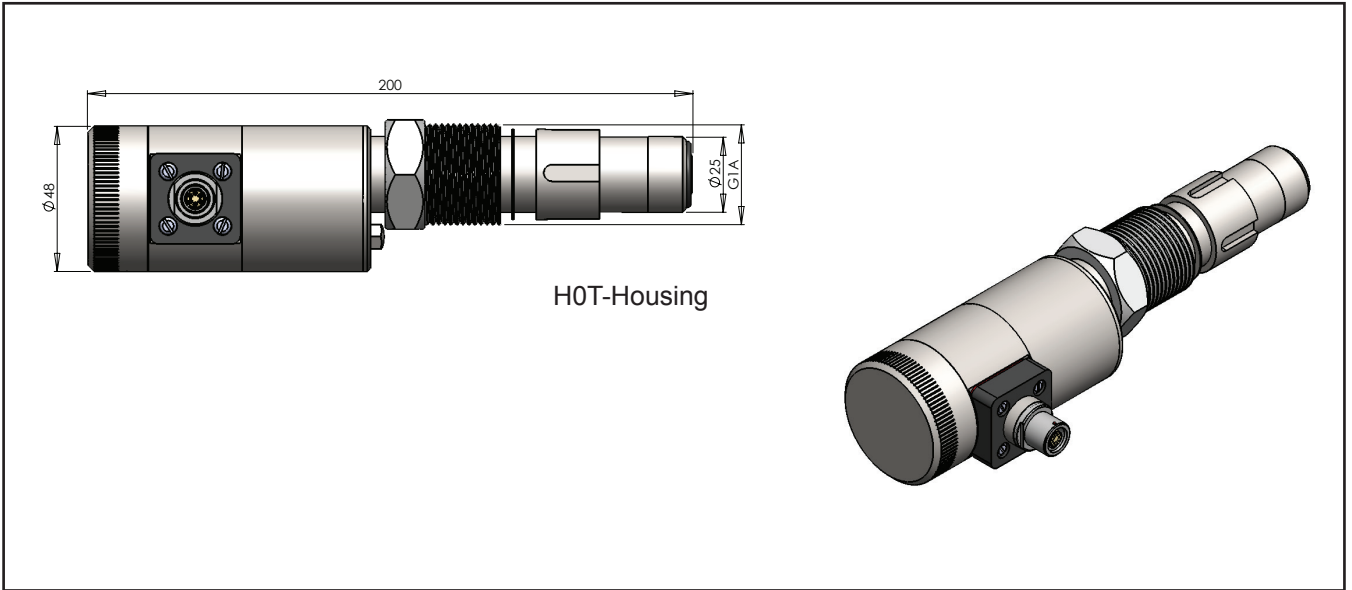

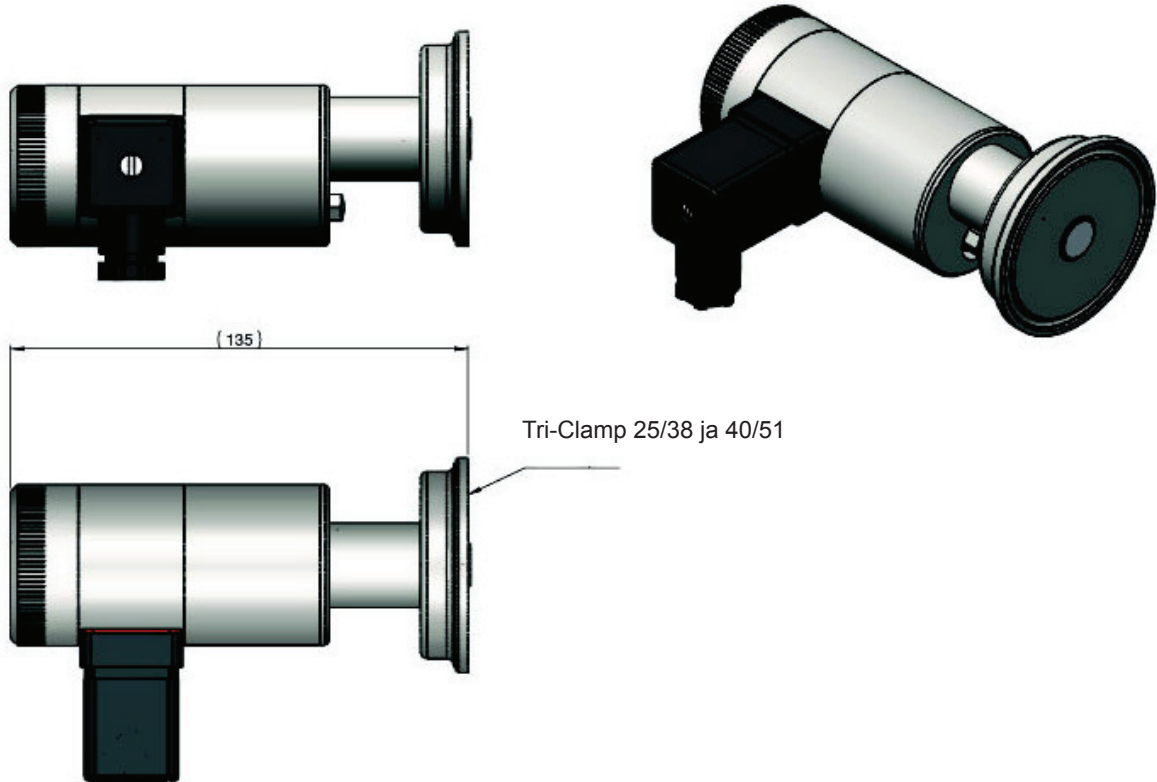

VOM with Tri-Clamp process connections, codes TA and TB

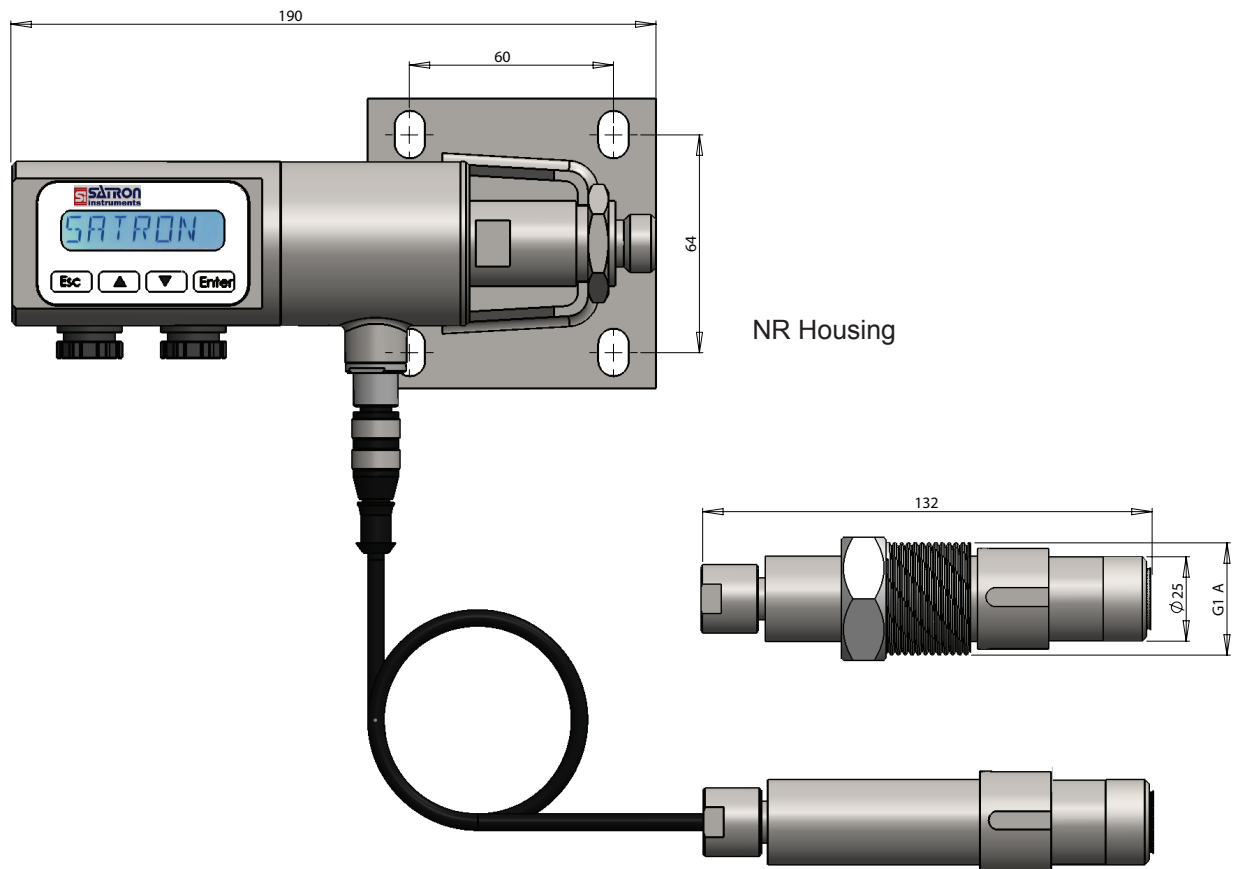

VOM with remote sensor, housing type code R

**Dimensions and housing type VOF**

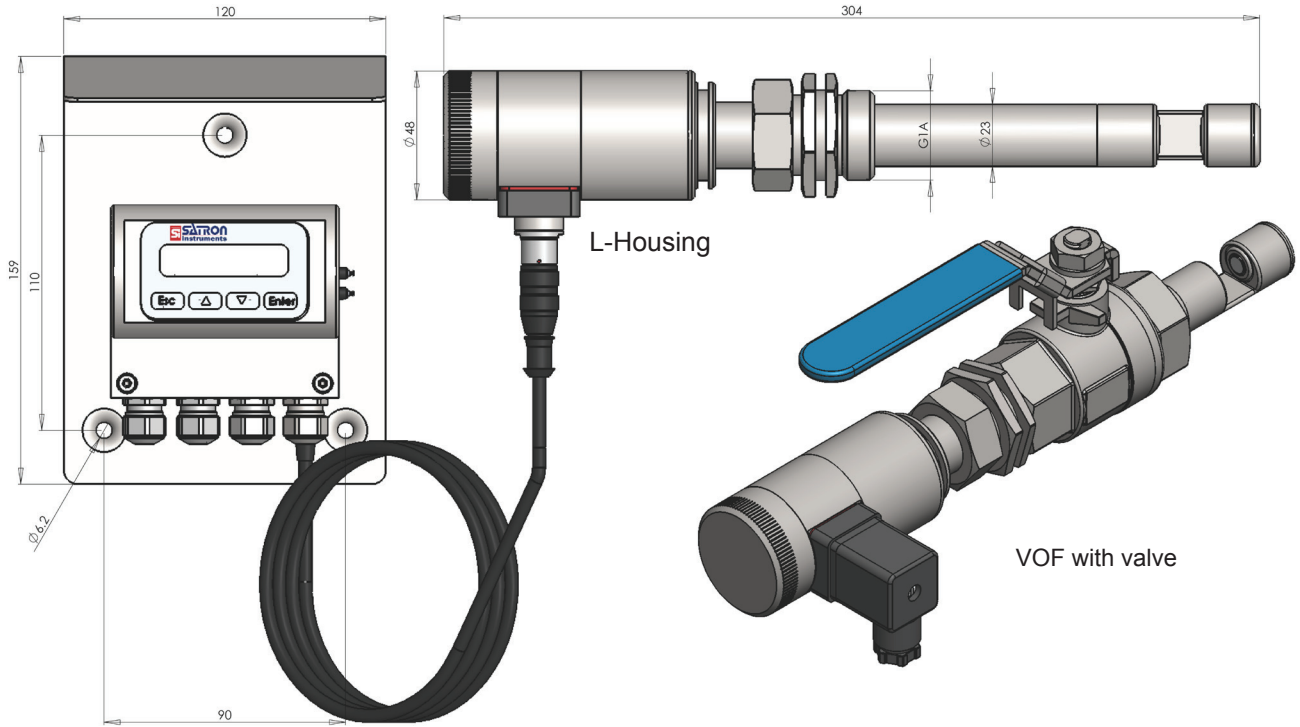
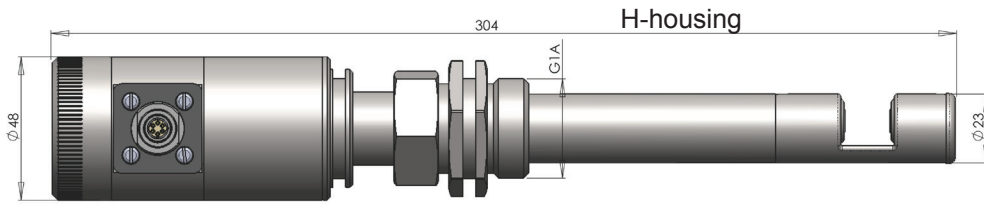

**Dimensions and housing type VOD**

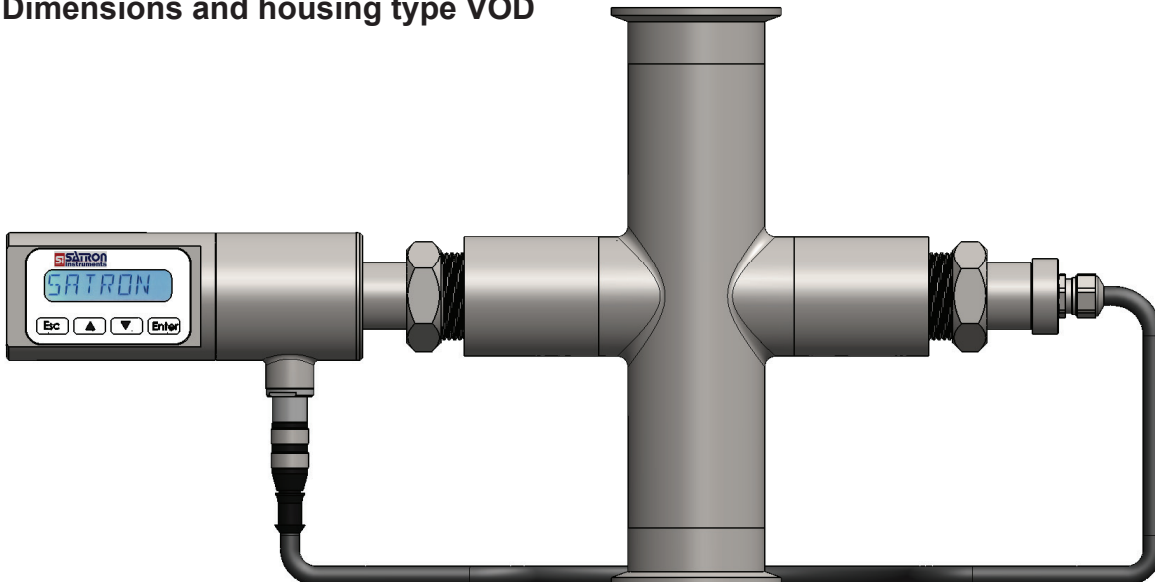

For easy installation the VOD is available with many different process connections. Such as:

- DN50 PN40
- DN100 PN40
- Tri-Clamp DN38, DN51, DN63,5
- Sandvik DN70 PN40
- SMS38
- SMS51
- Tuchenhagen / Varivent

Contact Satron for other possibilities



SATRON VO Turbidity and solids content analyzer

### 1.2 Electrical connections

Supply voltage and load of the transmitter according to the figure 1-16.

We recommend shielded twisted-pair cable as signal cable.

The signal cable should not be installed near high-voltage cables, large motors or frequency converters.

The shield of the cable is grounded at the power supply end or according to the recommendations of the manufacturer of the used control system.

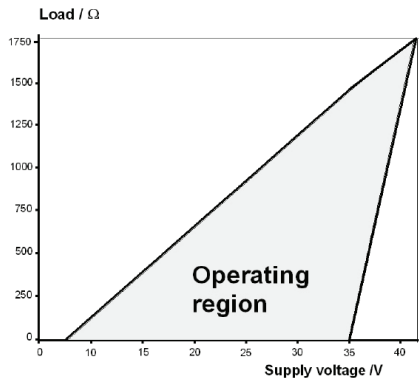

Min. load using HART® - communication 250 Ω

$$R_{max} = \frac{\text{Supply voltage} - 5 \text{ V}}{I_{max}}$$

$I_{max} = 20.5 \text{ mA}$  using HART®-communication

$I_{max} = 23 \text{ mA}$  (when the alarm current 22,5 mA is on)

Figure 1-16

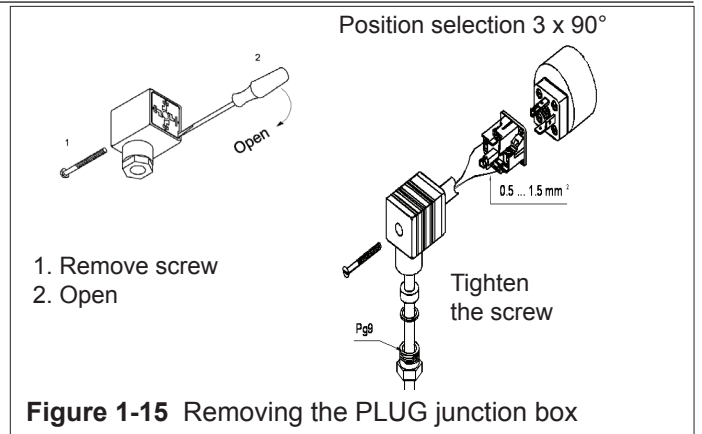

Figure 1-15 Removing the PLUG junction box

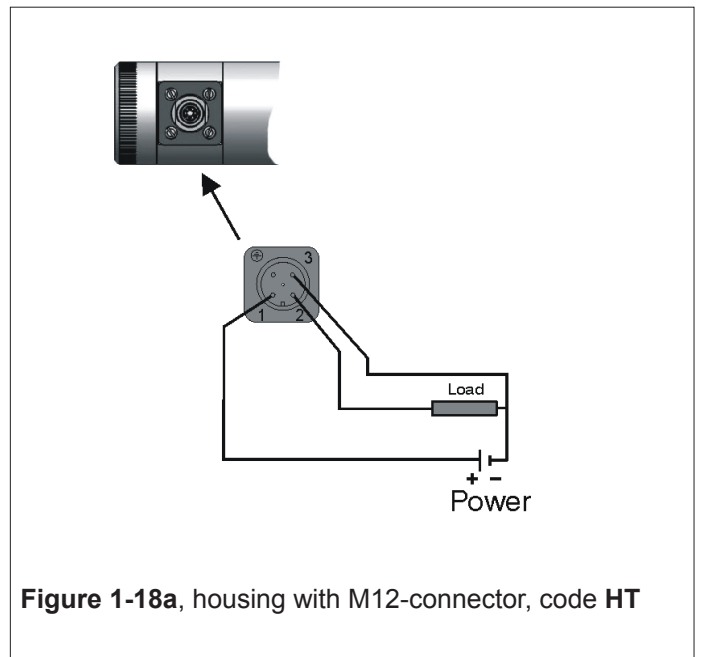

Figure 1-18a, housing with M12-connector, code HT

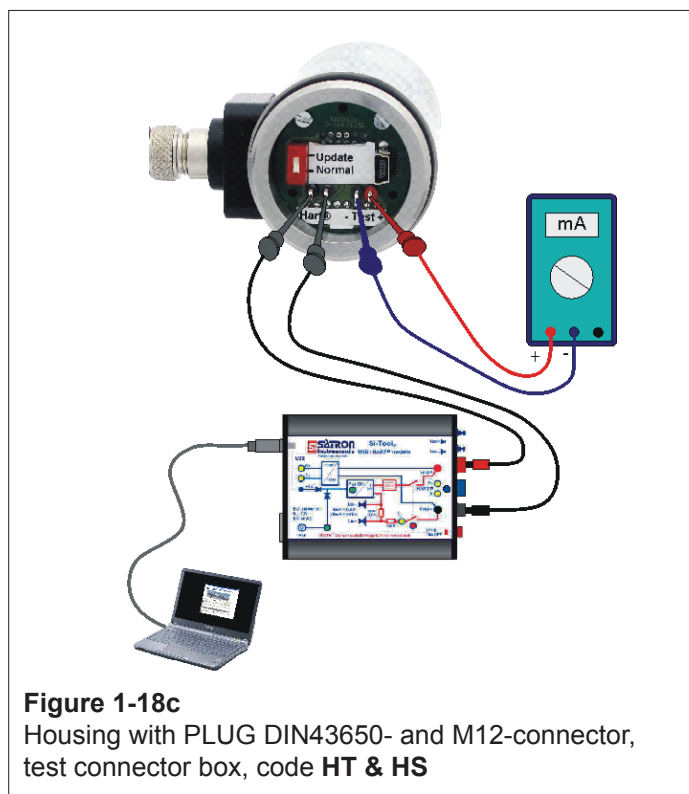

Figure 1-18c  
 Housing with PLUG DIN43650- and M12-connector, test connector box, code HT & HS

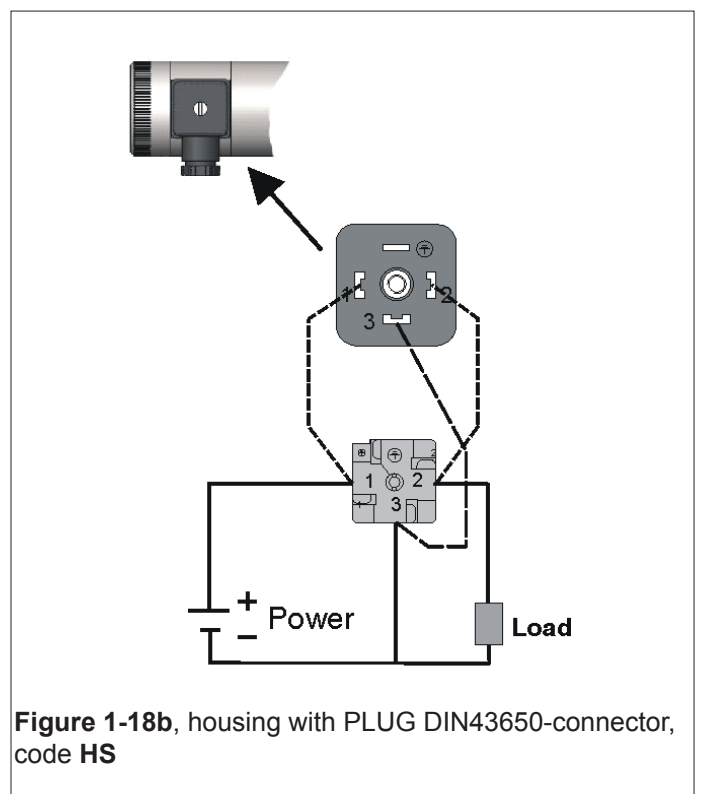
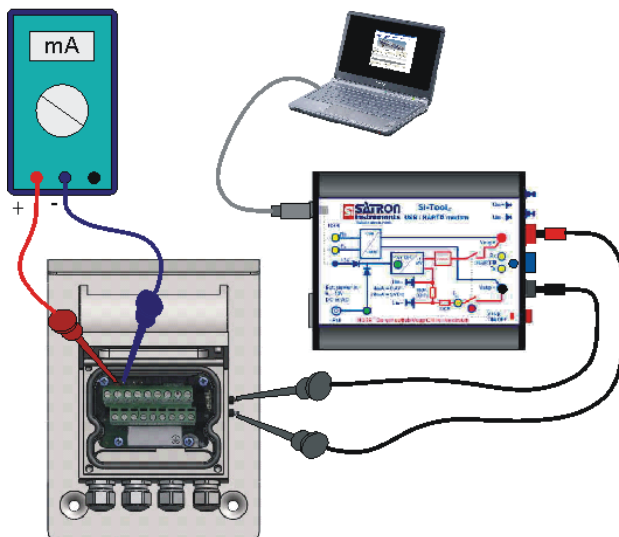
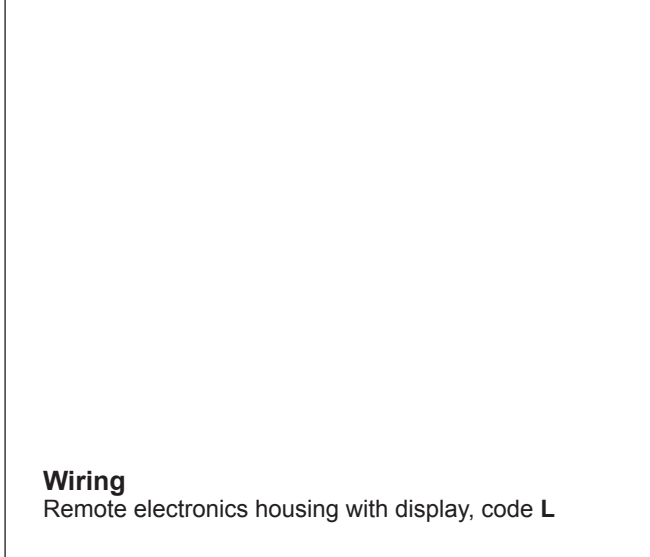
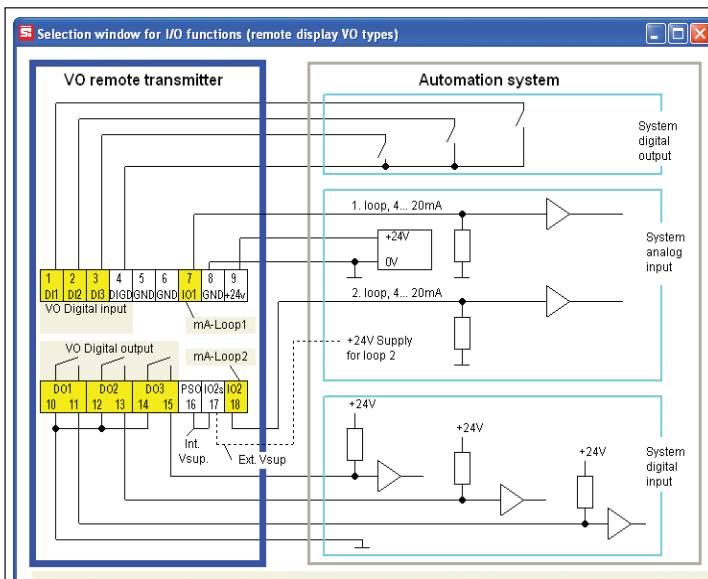
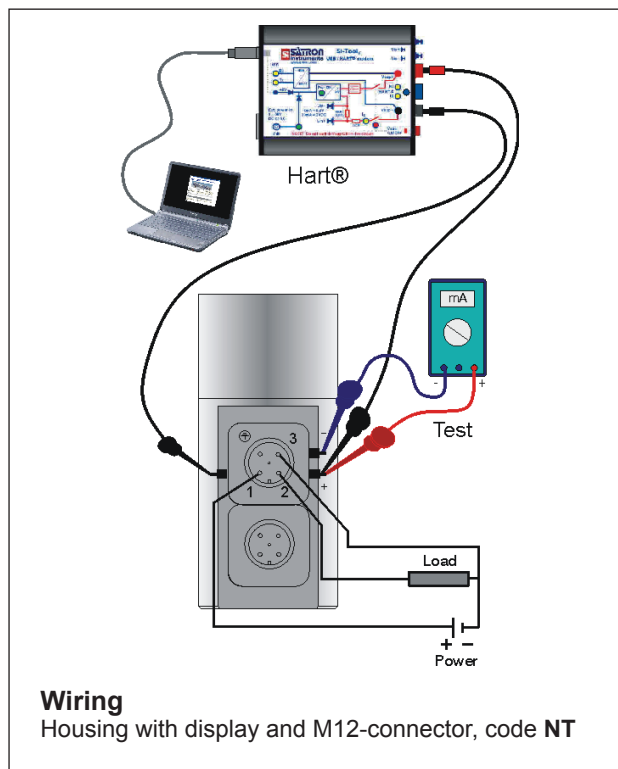
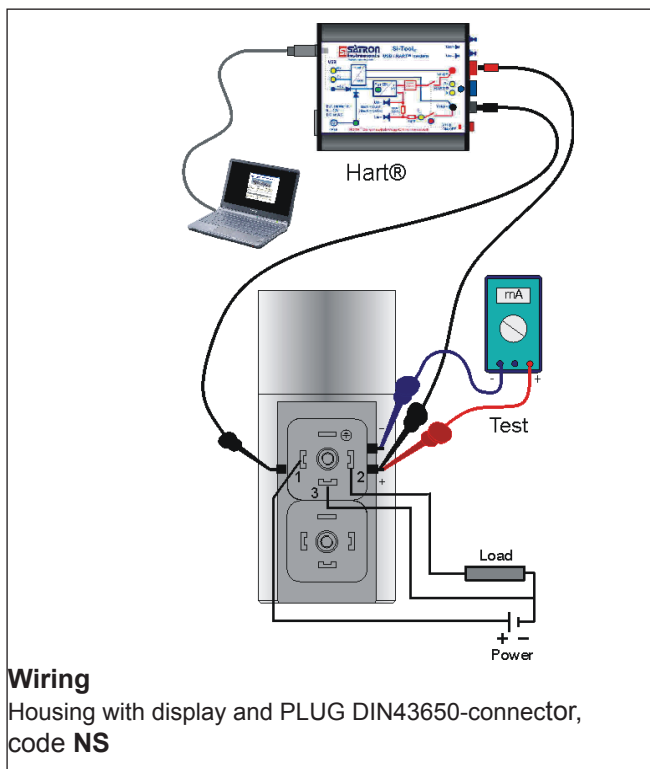

Figure 1-18b, housing with PLUG DIN43650-connector, code HS

SATRON VO Turbidity and solids content analyzer



## 2.1 Setting-up with Satron-VoAdvisor Service Software

When you want to have all the operations of the Smart transmitter, we recommend the use of Satron-VOadvisor Service Software program. Satron Instruments Inc. will deliver you the program and HART-modem.

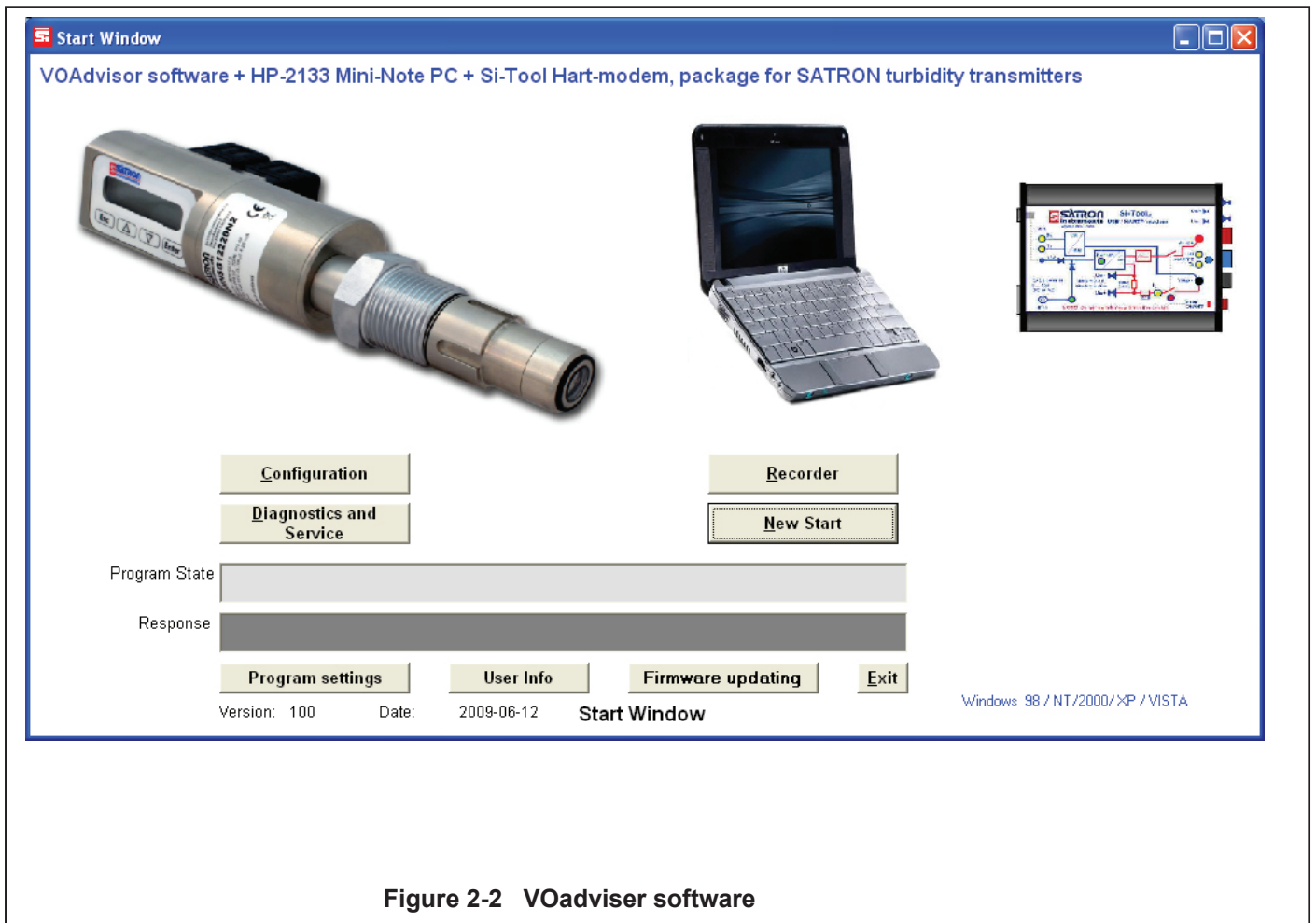
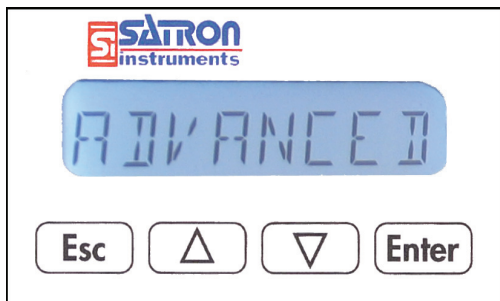

Figure 2-2 VOadvisor software

## 2.2 Setting-up with local switches

The additional instruction of display menus is enclosed to this manual. See chapter 3



### Housing with display, code N

Keyboard :

- Esc = Press **Esc** move back towards the top of the main menu.
- ▲ = Use the **UP** arrow key to move up on the current menu level or to increase the selected parameter value.
- ▼ = Use the **DOWN** arrow key to move down on the current menu level or to decrease the selected parameter value.
- Enter = Press **ENTER** to move to a lower level in a menu or to accept a command or parameter value.

### 2.3 Setting up with VO remote unit.

The Satron VO remote can be provided with a wall box which is capable of having a 20m cable between the Sensing unit and the Display unit. Inside the Display unit is a terminal where up to 3 binary inputs, 3 relay outputs and 2 analog milliamp loops can be connected. All connections can be used simultaneously. The signal cable between the Display unit and Sensing unit should not be installed near high-voltage cables, large motors or frequency converters.

**VO Remote Connections**

**VO Sensing connections.**  
 Inside the Sensing element is a dipswitch and a USB port. This is only used for updating the firmware.  
**DO NOT USE THE USB PORT UNLESS THERE NEEDS TO BE A NEW FIRMWARE INSTALLED.**

### 3. USER GUIDE FOR MENUS

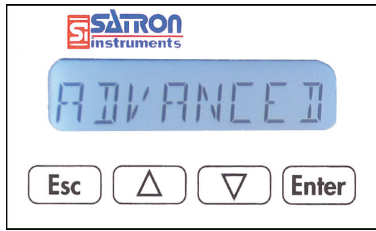

The user interface for the series VO analyzers, housing option N, consists of display and operating keys. Among other things, the user interface allows you to set process variables in the desired units on the display and to configure the analyzer e.g. by setting the lower and upper range-values. In addition, you can perform diagnostic routines and view device information through the user interface. The 8-character liquid crystal display (LCD) with backlight allows you to display information with letters and numbers.

**OPERATING KEYS:**

With the UP/DOWN arrow keys and the ENTER and ESC you can move in the menus.

**ENTER:**

Press ENTER to move to a lower level in a menu or to accept a command or parameter value.

**UP:**

Use the UP arrow key to move up on the current menu level or to increase the selected parameter value.

**DOWN:**

Use the DOWN arrow key to move down on the current menu level or to decrease the selected parameter value.

**ESC:**

Press the ESC to move back towards the top of the main menu or cancel the current action.

#### 3.1 MEASUREMENTS VALUES MENU:

When the analyzer is powered up, it immediately shows the MEASUREMENT VALUES. Use the UP/DOWN keys to move in the menu. The menu does not have any variables adjustable by the user.

Pressing DOWN shows you the following parameters in order.

- U the user calibrated information.
- DI03 the status of the digital input/output #3
- DI02 the status of the digital input/output #2
- DI01 the status of the digital input/output #1
- E the temperature of the electronics
- S the temperature of the sensor head
- MA the value of the first mA loop
- MA2 the value of the second mA loop
- % the selected UNIT for the user calibrated information. (%)

#### 3.2 MENU STRUCTURE

The VO analyzers equipped with a display and with Firmware version O120601A or later, the menu is split in to a "BASIC", and "FULL" structure. You can see the current firmware version during startup for 1 second. Or go to "INFO">"VERSION">"CPU FW", in the "FULL" structure menu.

For a quick 2 point calibration, checking the sensor status, alarms, or setting up damping for the measurement, entering the "BASIC" structure will fulfill. For more advanced settings like Language, in/out-put configuration, change of recipe, the "FULL" structure needs to be used.

### 4.1 Setting up with "BASIC"

To enter the "BASIC" structure menu:  
 Press ESC shortly, and 3 submenu's are accessible.

#### "CALIB" [CALIB]

This is the basic calibration mode. Here the 4mA and 20mA points can be changed. The result is always a linear 2 point calibration. You can change both 4mA and 20mA, or only one of them. The analyzer needs to be teached to the new calibration, by means of having the corresponding liquid in front of the lens. the analyzer will inform that the calibration will be erased. Confirm by pressing Enter.

#### "# 4 MA?" \* 4 MA?

Now the analyzer is asking for the 4mA value. Insert the analyzer in the corresponding liquid, wait 5 seconds and press enter.

#### "# 20 MA?" \* 20 MA?

Now the analyzer is asking for the 20mA value. Insert the analyzer in the corresponding liquid, wait 5 seconds and press enter.

By pressing ESC. the value will be left the same, allowing to for example only change the 4mA or only the 20mA. By pressing ESC. for each value the calibration procedure will be canceled totally.

#### "DIAGNOST" [DIAGNOST]

(see 4.2.5 for more information)

- STATUS
- LOOPTEST
- TRB TRIM
- ST TRIM
- LOOP CAL
- I/O TEST
- HARDWARE

#### "DAMPING" [DAMPING]

Time constant, in seconds for output damping. The range is 0.000s to 60s. Set the value with the UP/DOWN keys and accept it with ENTER or press ESC if you do not want to change the value.

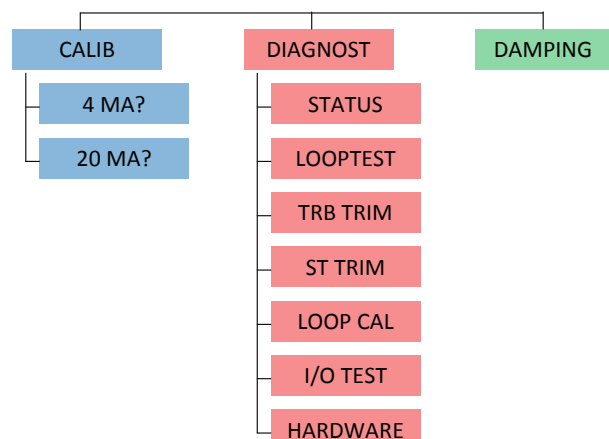

## 4.2 Setting up with "Full"

Under the full menu are 6 submenus: System configuration, Measurement configuration, Output- configuration, Info, Diagnostics and Advanced. To enter these submenus press ESC for 3 seconds. See page 18.

### 4.2.1 SYSTEM CONFIGURATION: **SYSTCONF**

(configure parameters that have an effect on the system like e.g. language and date.)

TAG: **TAG**

Tag code. You can enter free-format text one character at a time. When you select this option with **ENTER** the cursor will be at the left. Select characters with **ENTER** (to the right) and **ESC** (to the left). You can view the selectable characters one character at a time with the **UP/DOWN** keys until the desired character is found. When the cursor is at the right edge you can go back to the **SYSTCONF** menu either by accepting the new tag code with **ENTER** or by pressing exiting without changing the tag code by pressing the **ESC** key when asked to accept your entry. Apostrophe indicates the cursor position; at point, however, the cursor will disappear. A great deal of special characters are available besides letters and numbers.

FACTORY: **FACTORY**

Restore Factory settings. After entering this menu you will get a warning message that the configurations will be lost after this point. To cancel the procedure press **ESC**.

PASSWORD: **PASSWORD**

From this menu you can set a password (0...999) for the analyzer. If a password has been specified, you cannot set any parameters or make any other settings on the analyzer unless you enter the correct ID number in this menu. Password is not in use when **PASSWORD** is 000 after reset. You enter the **PASSWORD** in the same way as **TAG**. **PASSWORD** will be on when you define a value between 1 and 999. If you forget password get on to Satron Instruments Inc.

DISPLAY: **DISPLAY**

In this menu you can select the looks in which the display will be read.

**BACKLIGHT:** Select the intensity of the backlighting from **OFF, LOW, MEDIUM** and **HIGH**.

**ANGLE:** lets you select the angle of the text.

**NORMAL:** From left to right. Transmitter mounted horizontally with process connection directed to the right.

**ROTATED:** Rotates the text 180 degrees from **NORMAL**.

HART: **HART**

Select this function with the **UP/DOWN**[↑↓] keys. In menus 1-3 you select the content of the burst message. You can view the available selections with the **UP/DOWN**[↑↓] keys. Available options:

**In menu 1 (PV):** Transmitter sends process value PV to system.

**In menu 2 (PERCEN%):** Transmitter sends process variable's value in per cent of specified measuring range to master.

**In menu 3 (PVS/CURR):** Transmitter sends all process variables and current signal's value.

**In menu 5 (POLL ADR):** Select the transmitter's Hart® address. The address can be set between 0 and 15. Address 0 defines current loop, in which case the transmitter will operate in two-wire system. The procedure is the same as described above.

**In menu 6 (BURST ON/OFF):** Select the Burst mode. First define the process variable sent by the transmitter from menus 1-3. The procedure is the same as described above.

DATE: **DATE**

From this menu you can set the date DD.MM.YYYY. You enter the DATE in the same way as TAG.

The calendar year can be selected from between 1900 and 2155. This date can be example the date of the last calibration done.

LANGUAGE: **LANGUAGE**

Select the Display language.

*FINNISH, ENGLISH, SWEDISH, GERMAN, DUTCH, FRENCH.*

### 4.2.2 MEASCONF: **MEASCONF**

(configure parameters that have an effect on the measurement.)

DAMPING: **DAMPING**

Time constant, in seconds for output damping. The range is 0.000s to 60s. Set the value with the **UP/DOWN** keys and accept it with **ENTER** or press **ESC** if you do not want to change the value.

AVERAGE: **AVERAGE**

Time constant in Hz for averaging the output. The range is 1Hz to 50Hz. Set the value with the **UP/DOWN** keys and accept it with **ENTER** or press **ESC** if you do not want to change the value.

UNIT: **UNIT**

Here you can select what unit you want to show in the display as process value.

FNU, FTU, NTU, %, mg/L\*, ppm\*

\* only available in COD models.

**LED CURR:** Select the maximum amount of current that the LED is using in percentages.

### 4.2.3 I/O CONF: **I/O CONF**

(configure parameters that have an effect on the INPUT and OUTPUT relays).

Satron highly recommends the use of the software package VOadviser to alter these settings!

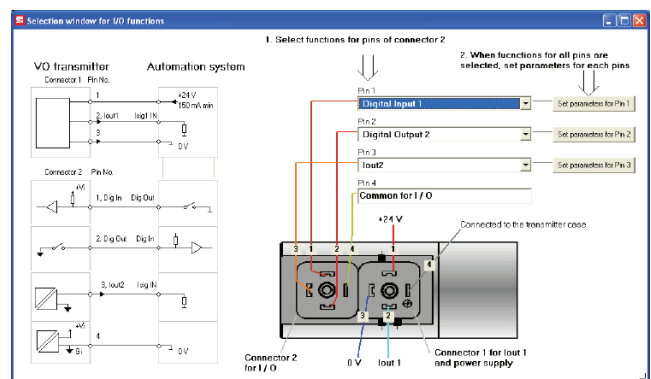

VoAdviser input / output configuration window

SATRON VO Turbidity and solids content analyzer

I/O 1: I/O 1

Settings menu for input / output PIN #1.

TYPE: TYPE

Select the function.

When "NONE" is selected it will be off. To use it as a digital input, select DIN1. For digital output select DOUT1.

OF TIMER: OF TIMER

Overfeed timer limits the time that the digital output can be continuously in ON state.

The time can be selected in seconds in the range of 1...60000s. By default the overfeed timer is not used.

Note: overfeed timer does not function if digital output is overridden by HOLD function, when performing a I/O test in the DIAGNOST menu or with HART CPU Control/ DOOverride.

OF DELAY: OF DELAY

Off delays can be used to delay digital output state from ON > OFF transitions. The time can be selected in seconds in the range of 0...300s. By default the off delay is not used.

ON DELAY: ON DELAY

On delays can be used to delay digital output state from OFF > ON transitions. The time can be selected in seconds in the range of 0...300s. By default the off delay is not used.

DEADBAND: DEADBAND

Select the deadband area. In this area the state will not change to prevent fast ON/OFF switching. By default this area is 0.

LO VALUE: LO VALUE

Enter the lower limit value for the state transition of the digital output

HI VALUE: HI VALUE

Enter the upper limit value for the state transition of the digital output

SWITCH: SWITCH

Change the direction of the transition change of the digital output

SOURCE: SOURCE

Select the source to which the digital output will change its state.

PV is the process value selected by the user. (value which is behind "U" on the display).

MA is the 1st current loop

ST is the sensor temperature located 5 millimeter behind the optical lens

RANGE-% this will show a 0 to 100 % value correlating to 4...20mA.

FUNCTION: FUNCTION

HI LIMIT the digital output will change its state depending on the HI VALUE

LO LIMIT the digital output will change its state depending on the LO VALUE

HILO LIMIT the digital output will change its state depending on the HI and LO VALUE

ERROR AL the digital output will change its state when there is an error

WRNG AL the digital output will change its state when there is a warning

ERWNG AL the digital output will change its state when there is a error and/or warning

HOLD when the digital input is ON the whole unit will be in a hold until the input is OFF.

NONE no function.

I/O 2: I/O 2

Settings menu for input or output PIN #2.

TYPE: TYPE

When "NONE" is selected it will be off. To use it as a digital input, select DIN2. For digital output select DOUT2. When the second current loop is used with an external power supply this needs to be set at IO2EXT.

OF TIMER: OF TIMER

Overfeed timer limits the time that the digital output can be continuously in ON state.

The time can be selected in seconds in the range of 1...60000s. By default the overfeed timer is not used.

Note: overfeed timer does not function if digital output is overridden by HOLD function, when performing a I/O test in the DIAGNOST menu or with HART CPU Control/ DOOverride.

OF DELAY: OF DELAY

Off delays can be used to delay digital output state from ON > OFF transitions. The time can be selected in seconds in the range of 0...300s. By default the off delay is not used.

ON DELAY: ON DELAY

On delays can be used to delay digital output state from OFF > ON transitions. The time can be selected in seconds in the range of 0...300s. By default the off delay is not used.

DEADBAND: DEADBAND

Select the deadband area. In this area the state will not change to prevent fast ON/OFF switching. By default this area is 0.

LO VALUE: LO VALUE

Enter the lower limit value for the state transition of the digital output

HI VALUE: HI VALUE

Enter the upper limit value for the state transition of the digital output

SWITCH: SWITCH

Change the direction of the transition change of the digital output

SOURCE: SOURCE

Select the source to which the digital output will change its state.

PV is the process value selected by the user. (value which is behind "U" on the display).

MA is the 1st current loop

ST is the sensor temperature located 5 millimeter behind the optical lens

RANGE-% this will show a 0 to 100 % value correlating to 4...20mA.

FUNCTION: FUNCTION

HI LIMIT the digital output will change its state depending on the HI VALUE

LO LIMIT the digital output will change its state depending on the LO VALUE

HILO LIMIT the digital output will change its state depending on the HI and LO VALUE

ERROR AL the digital output will change its state when there is an error

WRNG AL the digital output will change its state when there is a warning

ERWNG AL the digital output will change its state when there is a error and/or warning

HOLD when the digital input is ON the whole unit will be in a hold until the input is OFF.

NONE no function.

SATRON VO Turbidity and solids content analyzer

I/O 3: I/O 3

Settings menu for input or output PIN #3.

TYPE: TYPE

When "NONE" is selected it will be off. To use it as a digital input, select DIN3. For digital output select DOUT3. The enable the second miliamp loop select IO2.

OF TIMER: OF TIMER

Overfeed timer limits the time that the digital output can be continuously in ON state.

The time can be selected in seconds in the range of 1...60000s. By default the overfeed timer is not used.

Note: overfeed timer does not function if digital output is overridden by HOLD function, when performing a I/O test in the DIAG-NOST menu or with HART CPU Control/ DOOverride.

OF DELAY: OF DELAY

Off delays can be used to delay digital output state from ON > OFF transitions. The time can be selected in seconds in the range of 0...300s. By default the off delay is not used.

ON DELAY: ON DELAY

On delays can be used to delay digital output state from OFF > ON transitions. The time can be selected in seconds in the range of 0...300s. By default the off delay is not used.

DEADBAND: DEADBAND

Select the deadband area. In this area the state will not change to prevent fast ON/OFF switching. By default this area is 0.

LO VALUE: LO VALUE

Enter the lower limit value for the state transition of the digital output

HI VALUE: HI VALUE

Enter the upper limit value for the state transition of the digital output

SWITCH: SWITCH

Change the direction of the transition change of the digital output

SOURCE: SOURCE

Select the source to which the digital output will change its state.

PV is the process value selected by the user. (value which is behind "U" on the display).

MA is the 1st current loop

ST is the sensor temperature located 5 millimeter behind the optical lens

RANGE-% this will show a 0 to 100 % value correlating to 4...20mA.

FUNCTION: FUNCTION

HI LIMIT the digital output will change its state depending on the HI VALUE

LO LIMIT the digital output will change its state depending on the LO VALUE

HILO LIMIT the digital output will change its state depending on the HI and LO VALUE

ERROR AL the digital output will change its state when is an error

WARNG AL the digital output will change its state when there is a warning

ERWNG AL the digital output will change its state when there is a error and/or warning

HOLD when the digital input is ON the whole unit will be in a hold until the input is OFF.

NONE no function.

4.2.4. OUTPCONF OUTPCONF

(configure parameters that have an effect on the output current loops). Change the recipe and perform new calibrations.

RECIPE RECIPE

Upto 4 different recipe's can be stored in the VO. The basic factory calibration is stored standard in Recipe 1.

To perform a new calibration its recomended to use a different recipe.

LIN FUNC: LIN FUNC

Change the transfer function between USER and LINEAR.

LINEAR is the standard linear transfer function using lower and upper range values. (LRV & URV)

This transfer function is used for scaling mA, it does NOT change the process value PV. The user point table is not in use.

USER is the default transfer function, in which the process value PV can be changed using 2...16 calibration point pairs.

USER.PNTS: USERPNTS

With the LIN FUNC selected as USER, the number of points is selected with the counter.

POINT.CNT Point counter for selecting the amount of calibration points. 1...16.

POINT 1...16 By selecting SAMPLE for the corresponding point, a realtime measurement will start and when the user presses "ENTER" the unit will average the sample currently measuring and save this for the current point number. The first point corresponds to 4mA output and the last point corresponds to 20mA output.

By using the edit function the user is able to alter the raw Please refer to the chapter CALIBRATION EXAMPLE of this manual to find more detailed information how to perform a full re-calibration.

USER MODE: USERMODE

Select the interpolation method between points.

INTERPL selects linear interpolation.

SPLINE selects spline interpolation.

4.2.4. INFO: INFO

MANUFACTURER: MANUFCTR

Manufacturer's name. (SATRON) Cannot be changed.

OPERATION TIME: OP TIME

The value of the operation time save at 1 hour intervals. When the value of the counter is < 100 hours so value save 1- minute intervals. The value of the operation time counter on the display :

HH :MM :SS when the value of counter is <100 hours

HHHH : MM when the value of counter is <100000 hours

HHHHHHHH when the value of counter is ≥100000 hours

SERIAL NUMBER: SER NUM

Serial number. Cannot be changed.

ASSEMBLY NUM: ASSM NUM

The analyzers assembly number. Press ENTER to select this item. Press ESC to exit. For instance, assembly number 0901 shows that the transmitter was made in week 01 of the year 2009.

VERSION: VERSION

Version numbers of the transmitter's electronics and software. Press ENTER to select this item. Press ESC to exit. With the UP/DOWN keys you can select either CPU HW, CPU SW, ADC HW, ADC SW or MAN REV (manual revision) revision number



SATRON VO Turbidity and solids content analyzer

or CPU ID-number from this submenu.

DEVICE TYPE: DEV TYPE

Product type code. Cannot be changed.

#### 4.2.5. DIAGNOSTICS: DIAGNOST

(This submenu allows you to examine the transmitter's internal errors and faults, to set the transmitter to give out a fixed current, and to calibrate the transmitter.)

STATUS: STATUS

Here you can display and reset accumulated errors one at a time. The text OK will be displayed if there are no errors. Possible error messages (alarm means a serious fault/error that also puts the current signal in fault status and makes the display blink)

LOOPTEST: LOOPTEST

The transmitter can be set to give out a fixed current signal for testing the mA output. The first ENTER will switch the transmitter off from normal mode (AUTO OFF), the second ENTER will set it for 4 mA output, and the third ENTER for 20 mA output. The next ENTER after that will give default value 12 mA, which can be changed as desired with the UP/DOWN keys. The last ENTER will switch the transmitter back to normal mode (AUTO ON). The purpose of this test is to test the accuracy of the transmitter's current output with a reference meter.

LOOPCALIBRATION: LOOPCAL

Here you can calibrate the current signal given by the transmitter. The first ENTER will switch the transmitter off from normal mode (AUTO OFF). The next ENTER will make the transmitter give out a signal which it assumes to be 4 mA. Use the UP/DOWN keys to change this value in accordance with the reading on the reference meter. Then press ENTER for 20 mA output, which you must also set in accordance with the reference meter. Press ENTER to accept the new reading.

Note: Use a sufficiently accurate reference meter.

SENSOR TEMPERATURE TRIM: ST TRIM

Sensor Temperature Trim. Here you are able to calibrate the temperature probe which is placed in the head of the analyzer. (Maximum by 10 degrees.)

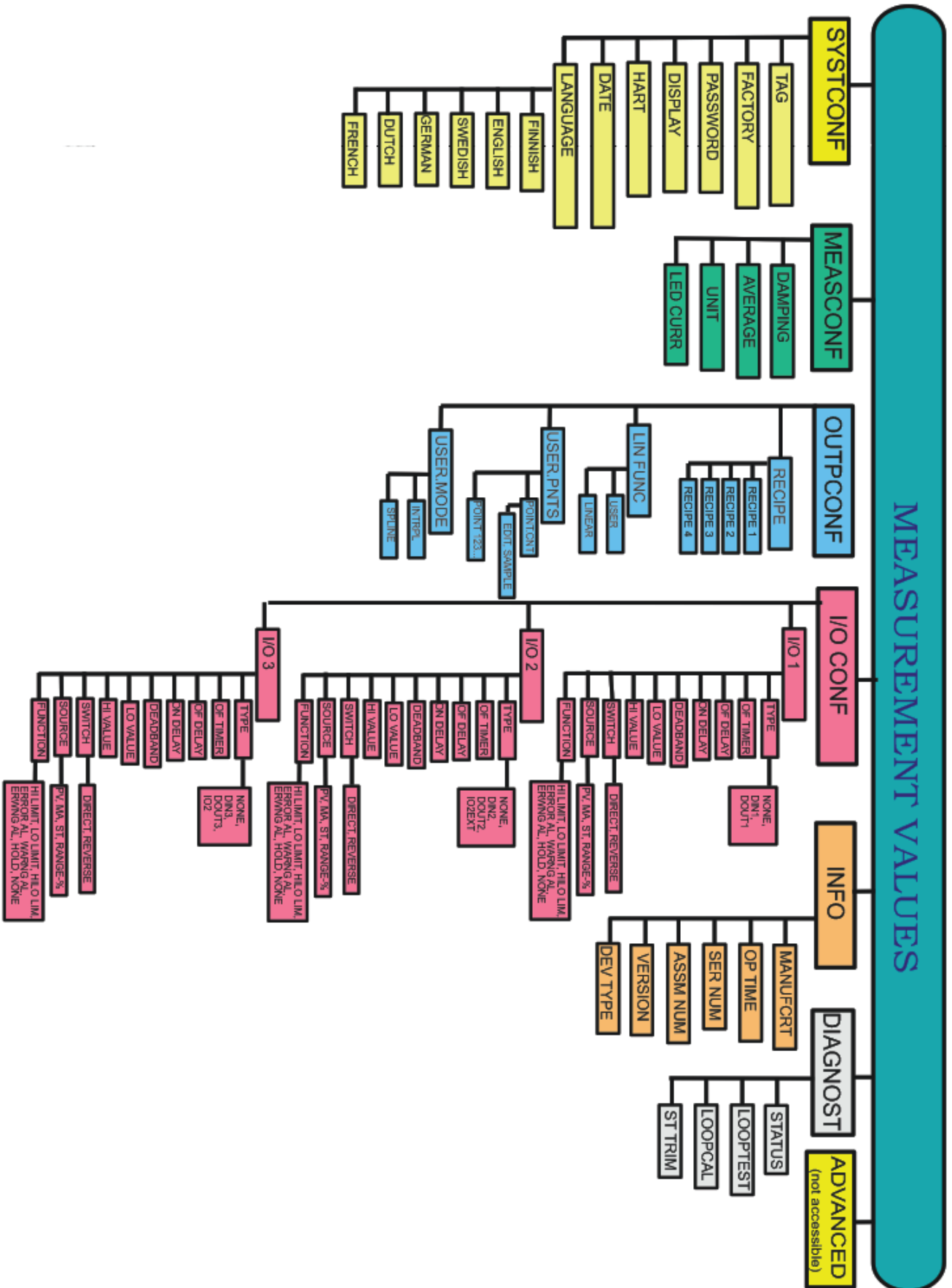

## 5 Set-up Calibration.

The VO series analyzer comes with a standard factory calibration.

There is space for 4 different calibrations, called recipe 1, 2, 3 and 4. Standard the factory calibration is stored in recipe 1. The different recipes can be renamed and also be enabled with the binary inputs.

To change a calibration Satron recommends to use the "VoAdvisor" software. It is also possible to change the calibration with the use of the sensors own user interface.

### Change recipe.

The current enabled recipe is shown with the down arrow when the normal user value (in measurement values) is shown.

To enable a different recipe go to **OUTPCONF** and **RECIPE**

Here you can choose between 1, 2, 3 and 4. Press enter to save.

### 2 point calibration guide.

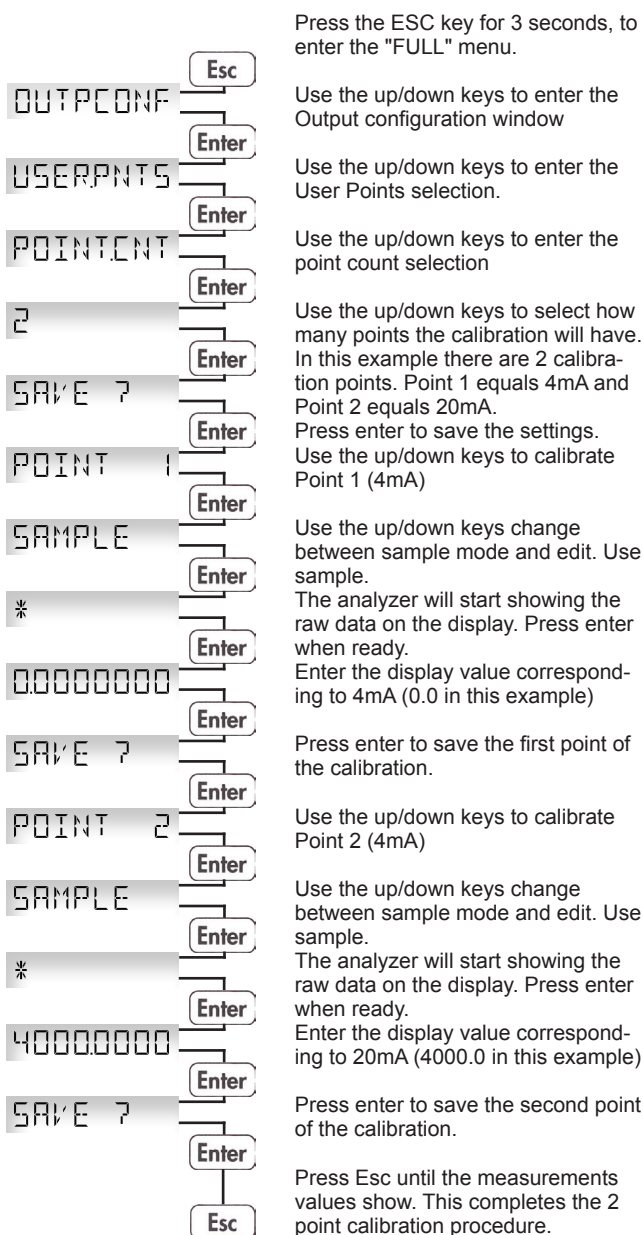

### 1 point calibration guide.

The unit is calibrated with 1 known sample. This is the Center point. In this example the Center point is equal to 2000.

The 4mA value is selected as -75% from the center point (500). The 20mA value is selected as +50% from the center point (3000). Calibration is 4mA=500 20mA=3000.

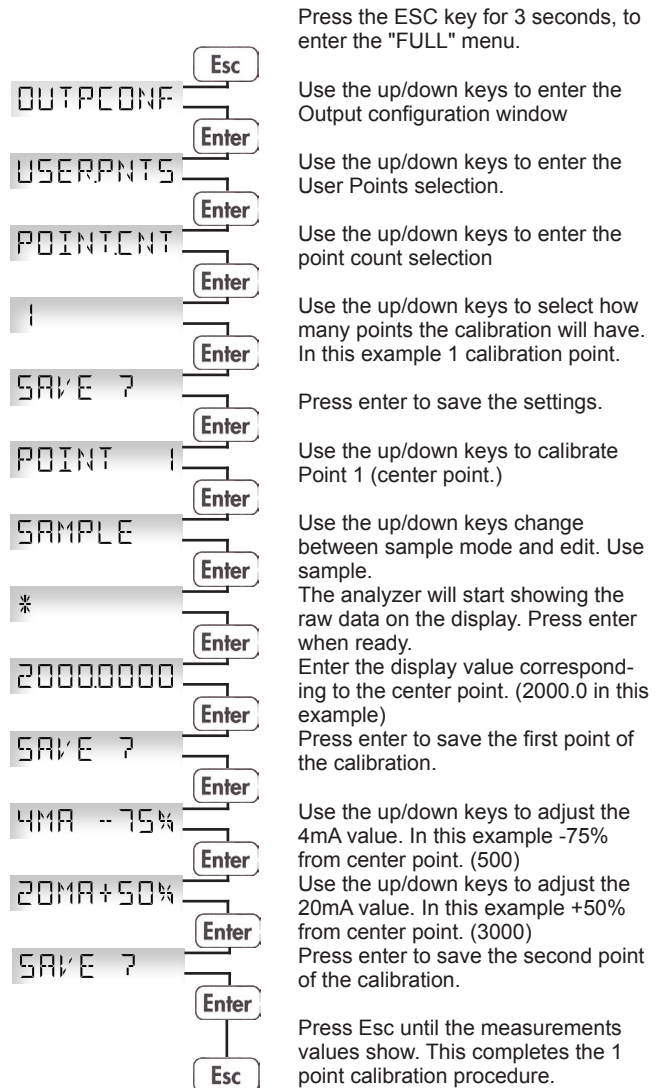



MEETS THE COUNCIL OF THE EUROPEAN UNION DIRECTIVE  
89/336/EEC FOR ELECTROMAGNETIC COMPATIBILITY  
REQUIREMENTS.



**Satron Instruments Inc.**

[www.satron.com](http://www.satron.com)

P.O.Box 22, FI-33901 Tampere, Finland

Tel.int. +358 207 464 800, Telefax +358 207 464 801

# SATRON VO Turbidity and solids content sensor

**SATRON VO turbidity and solids content analyzer** is suitable for the measurement of different liquids. Savings can be obtained by using SATRON VO analyzer in process industries, e.g. the use of clean water can be minimized, the time used for the cleaning (CIP) will be shortened, the use of the end product (in dairy applications: milk) and the use of cleaning materials needed in the process can be optimized. The transmitter communicates digitally using the HART® protocol.



## TECHNICAL SPECIFICATIONS

### Measuring range and span

See Selection Chart.

### Zero and Span adjustment

Zero elevation: Calibrated span is freely selectable on the specified range depending from the desired option. This can be made by using keyboard (display option) or HART®275/375 communicator.

### Damping

- Time constant is continuously adjustable 0.01 to 60 s.

### Repeatability

- 0.1% from maximum span.

### Temperature limits

Ambient: -30 to +80 °C  
Process: 0 to +100 °C / +140 °C (VOF)  
-5 to +100 °C / +140 °C (VOM & VOD)  
Shipping and storage: -40 to +80 °C.

**Output** 3-wire (3W), 4-20 mA

### Supply voltage

Nominal 24 VDC, (21,6 - 27,6V)

**Humidity limits** 0-100 % RH

### EMC directive 2004/108/EC

- EN 61326-1:2005

### CONSTRUCTION

#### Materials:

Sensing element <sup>1)</sup>: AISI316L, Duplex (EN. 1.4462), Hast. C276/C22, or Titanium Gr2.  
Surface quality: Polished Ra <0,8µm  
Lens: quartz glass, Safir glass or PC plastic  
Coupling <sup>1)</sup>: AISI316L, Duplex (EN 1.4462), Hast.C276 or Titanium Gr2  
Other sensing element materials: AISI316, SIS 2343.

### Pressure class:

- PN40  
- Test pressure -1 to 30 bar

### Housing with display,

codes **NOS & NOT**:  
Housing: AISI303/316, Seals: Nitrile-rubber and Viton®,  
Nameplates: Polyester

### Housing with M12 connector, code

**HOT**: Housing: AISI303/316, Seals:

Viton® and NBR.

### Housing with PLUG DIN 43650 connector, code **HOS**:

Housing: AISI303/316, Seals: Viton® and NBR.  
PLUG connector: PA6-GF30 jacket, Silicone rubber seal, AISI316 retaining screw.

### Connection hose between sensing element and housing

Codes **L** and **R** :  
PUR signal cable or hose protected with PTFE/AISI316 braiding

### Calibration

For customer-specified range with minimum damping. (If range is not specified, transmitter is calibrated for maximum range.)

### Electrical connections

Housing with PLUG connector, code **HOS**:  
Connector type DIN 43650 model AF; Pg9 gland for cable; wire cross-section 0.5 to 1.5 mm<sup>2</sup>.

Housing with M12 connector, code **HOT**:  
M12 plug connector

Housing with display, code **NOS**:  
Connector type DIN 43650 model AF; Pg9 gland for cable; wire cross-section 0.5 to 1.5 mm<sup>2</sup>.

Housing with display, code **NOT**:  
M12 plug connector

### I/O-connections

#### bout1-3

Relay, grounding contact  
Maximum voltage 35 V  
Maximum current 50 mA  
Maximum leakage current 10 µA

#### bin1-3

NC (no connection) OFF  
0...2 V ON

Minimum values for switch in use

Voltage 16 V  
Current 4 mA  
Leakage current 1 mA

Current output1  
Range 3.5...23 mA  
Maximum load 600 Ω  
Factory setting 4...20 mA

Current output2

Internal power supply

Current output 2 has same ground as binary IO

Maximum load 400 Ω

Range 3.5...23 mA

Factory setting 4...20 mA

External power supply

Current output 2 is galvanically isolated

Maximum supply voltage 35 VDC

Range 3.5...23 mA

Factory setting 4...20 mA

Maximum load, See picture below

Maximum isolation voltage 100 VDC

### Process connections

- With G1 connecting thread  
- Tri-Clamp 25/38 and 40/51

**Protection class:** See Selection chart.

### Weight

Housing with PLUG DIN43650 connector (**HOT**): 0.9 kg

Housing with M12 connector (**HOS**): 0.9 kg

Housing with display (**NOS & NOT**): 1.3 kg

Remote Housing (**L**): 2.5 kg

Remote sensor (**R**): 2.5 kg

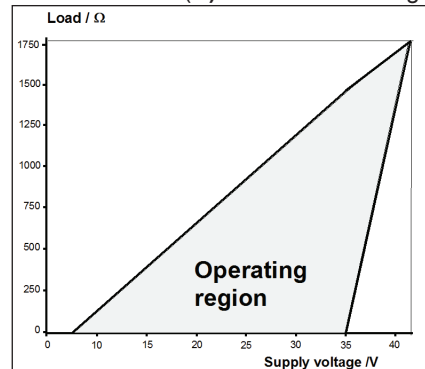

Min. load using HART®-communication 250 R

R max =  $\frac{\text{Supply voltage} - 5 \text{ V}}{I \text{ max}}$

I max = 20,5 mA

I max = 22,5 mA

(when the alarm current 22,5 mA is on)

Current output 2

External power supply

<sup>1)</sup> Parts in contact with process medium

## Selection Chart

<b>Adjustability</b>		<b>Span, min</b>		<b>Span, max</b>		
<b>VOM</b>		1000 FTU		5000 FTU		
<b>VOF(*)</b>		50 FTU		1500 FTU		
<b>VOD</b>		50 FTU		1500 FTU		
<b>Process temperature limits</b>	<b>N</b>	Normal version -5...+100 °C (VOM & VOD), 0...+100 °C (VOF)				
	<b>H(**)</b>	High temperature -5...+140 °C (VOM & VOD), 0...+140°C (VOF)				
<b>Output</b>	<b>S</b>	4-20mA DC/HART® for use with 230VAC 50Hz				
	<b>J</b>	4-20mA DC/HART® for use with 110VAC 60Hz				
<b>Material of wetted parts</b>	<b>Body</b>	<b>2</b>	AISI316L	<b>Lens</b>	<b>2</b> Sapphire glass	
		<b>3</b>	Hast. C 276		<b>4</b> Spinel	
		<b>6</b>	Titanium Gr2		<b>Seal</b>	
		<b>8</b>	Duplex (EN 1.4462)		<b>1(***)</b> EPDM	
		<b>9</b>	Peek		<b>2</b> FPM (Viton®)	
				<b>3</b> FFPM (Kalrez®)	<b>3A 18-03</b> Class II	
					Class I	
					Class I	
<b>Housing type</b>	<b>N</b>	Housing with display and pushbuttons				
	<b>H</b>	Housing with, no display, (only one mA output)				
	<b>L</b>	Remote electronics housing with display				
<b>Probe type</b>	<b>0</b>	No remote probe				
	<b>R</b>	Remote measuring probe (not available with L housing), IP68				
<b>Connection type</b>	<b>S</b>	DIN43650 with PG9, IP66				
	<b>T</b>	M12, IP67				
	<b>V</b>	PG9 (always with L housing), IP66				
<b>Cable Material</b>	<b>0</b>	No VOD, L or R selected				
	<b>1</b>	PUR cable.				
	<b>2(*)</b>	AISI316L braided PTFE hose.				
	<b>3</b>	Steel reinforced PUR hose.				
	<b>4</b>	PVC cable				
<b>Cable length</b>	<b>0</b>	No VOD or L, R option selected				
	<b>1</b>	5 M.	<b>3</b>	15 M. (PUR std.)	<b>5</b>	25 M.
	<b>2</b>	10 M. (PVC std.)	<b>4</b>	20 M.		...
<b>Light source</b>	<b>2</b>	365nm	<b>4</b>	540nm	<b>6</b>	640nm
	<b>3</b>	460nm	<b>5</b>	580nm	<b>7</b>	880nm
<b>8</b>						950nm
<b>Process connections</b>						
<b>G1</b>	Standard G1A thread + Oring					
<b>TA</b>	Tri-Clamp 25/38 (ISO 2852)					
<b>TB</b>	Tri-Clamp 40/51 (ISO 2852)					
<b>TN</b>	Tuchenhagen "N" type DN50					
<b>HX(*)</b>	Fixed mounting tube, (specify length)					
<b>B1(*)</b>	G1A ball valve insertion. Extension 19cm diameter ø 24mm					
<b>BX(*)</b>	G1A ball valve insertion. Extension by request diameter ø 24mm					



<b>Documentation</b>	
<b>Calibration certificate</b>	<b>AE</b> English
<b>Installation and operating instructions</b>	<b>IE</b> English <b>IF</b> Finnish <b>FR</b> French
<b>Material certificates</b>	
<b>0</b>	No material certificate
<b>MC1</b>	Raw material certificate without appendices, in accordance with SFS-EN 10204-2.1 (DIN 50049-2.1) standard
<b>MC2</b>	Raw material certificate for wetted parts, in accordance with SFS-EN 10204-2.2 (DIN 50049-2.2) standard
<b>MC3</b>	Raw material certificate for wetted parts, in accordance with SFS-EN 10204-3.1 B (DIN 50049-3.1 B) standard

\* Not EHEDG certified & Not within the 3A approval  
 \*\* Only in combination with Quartz, Sapphire lens and Kalrez Seals. And only 880nm  
 \*\*\* Do not exceed above 8% fat content.

We reserve the right for technical modifications without prior notice.

HART is the registered trademark of HART Communication Foundation.  
 Pasve is the registered trademark of Satron Instruments Inc.  
 Hastelloy is the registered trademark of Haynes International.  
 Viton is the registered trademark of DuPont Down Elastomer.  
 3-A is a registered mark owned and administered by 3-A SSI.

