

Logix 510si Digital Positioner



Table of Content	Page
1 General Information	3
2 Unpacking	4
3 Logix 510si Overview	5
4 Specifications	5
5 Principle of Operation	6
6 Tubing	6
7 Wiring	7
8 Startup	8
8.1 Logix 510si Local Interface Operation	8
8.2 Operation of Configuration Dipswitch Setup	8
8.3 Setup of the Cal Dipswitches	9
8.4 Quick-Cal Operation	10
8.5 Local Control of Valve Position	10
8.6 Factory Reset	10
8.7 Loop Calibration	10
9 Error Codes	12
10 Version Number checking	14
11 Trouble Shooting	15

1 USING FLOWSERVE VALVES, ACTUATORS AND ACCESSORIES CORRECTLY

1.1 Using

The following instructions are designed to assist in unpacking, installing and performing maintenance as required on FLOWSERVE products. Product users and maintenance personnel should thoroughly review this bulletin prior to installing, operating or performing any maintenance.

In most cases FLOWSERVE valves, actuators and accessories are designed for specific applications (e.g. with regard to medium, pressure, temperature). For this reason they should not be used in other applications without first contacting the manufacturer.

1.2 Terms concerning safety

The safety terms **DANGER**, **WARNING**, **CAUTION** and **NOTE** are used in these instructions to highlight particular dangers and/or to provide additional information on aspects that may not be readily apparent.



DANGER: indicates that death, severe personal injury and/or substantial property damage will occur if proper precautions are not taken.



WARNING: indicates that death, severe personal injury and/or substantial property damage can occur if proper precautions are not taken.



CAUTION: indicates that minor personal injury and/or property damage can occur if proper precautions are not taken.



NOTE: indicates and provides additional technical information, which may not be very obvious even to qualified personnel.

Compliance with other, not particularly emphasised notes, with regard to transport, assembly, operation and maintenance and with regard to technical documentation (e.g. in the operating instruction, product documentation or on the product itself) is essential, in order to avoid faults, which in themselves might directly or indirectly cause severe personal injury or property damage.

1.3 Protective clothing

FLOWSERVE products are often used in problematic applications (e.g. extremely high pressures, dangerous, toxic or corrosive mediums). In particular valves with bellows seals point to such applications. When performing service, inspection or repair operations always ensure, that the valve and actuator are depressurised and that the valve has been cleaned and is free from harmful substances. In such cases pay particular attention to personal protection (protective clothing, gloves, glasses etc.).

1.4 Qualified personnel

Qualified personnel are people who, on account of their training, experience and instruction and their knowledge of relevant standards, specifications, accident prevention regulations and operating conditions, have been authorised by those responsible for the safety of the plant to perform the necessary work and who can recognise and avoid possible dangers.

1.5 Installation



DANGER: Before installation check the order-no, serial-no. and/or the tag-no. to ensure that the valve/actuator is correct for the intended application.

Do not insulate extensions that are provided for hot or cold services.

Pipelines must be correctly aligned to ensure that the valve is not fitted under tension.

Fire protection must be provided by the user.

1.6 Spare parts

Use only FLOWSERVE original spare parts. FLOWSERVE cannot accept responsibility for any damages that occur from using spare parts or fastening materials from other manufactures. If FLOWSERVE products (especially sealing materials) have been on store for longer periods check these for corrosion or deterioration before using these products. Fire protection for FLOWSERVE products must be provided by the end user.

1.7 Service / repair

To avoid possible injury to personnel or damage to products, safety terms must be strictly adhered to. Modifying this product, substituting nonfactory parts, or using maintenance procedures other than outlined in this instruction could drastically affect performance and be hazardous to personnel and equipment, and may void existing warranties. Between actuator and valve there are moving parts. To avoid injury FLOWSERVE provides pinch-point-protection in the form of cover plates, especially where side-mounted positioners are fitted. If these plates are removed for inspection, service or repair special attention is required. After completing work the cover plates must be refitted.

Apart from the operating instructions and the obligatory accident prevention directives valid in the country of use, all recognised regulations for safety and good engineering practices must be followed.

WARNING: *Before products are returned to FLOWSERVE for repair or service FLOWSERVE must be provided with a certificate which confirms that the product has been decontaminated and is clean. FLOWSERVE will not accept deliveries if a certificate has not been provided (a form can be obtained from FLOWSERVE).*



1.8 Storage

In most cases FLOWSERVE products are manufactured from stainless steel. Products not manufactured from stainless steel are provided with an epoxy resin coating. This means that FLOWSERVE products are well protected from corrosion. Nevertheless FLOWSERVE products must be stored adequately in a clean, dry environment. Plastic caps are fitted to protect the flange faces to prevent the ingress of foreign materials. These caps should not be removed until the valve is actually mounted into the system.

1.9 Valve and actuator variations

These instructions cannot claim to cover all details of all possible product variations, nor in particular can they provide information for every possible example of installation, operation or maintenance. This means that the instructions normally include only the directions to be followed by qualified personal where the product is being used for is defined purpose. If there are any uncertainties in this respect particularly in the event of missing product-related information, clarification must be obtained via the appropriate FLOWSERVE sales office.

2 UNPACKING

Each delivery includes a packing slip. When unpacking, check all delivered valves and accessories using this packing slip.

Report transport damage to the carrier immediately.

In case of discrepancies, contact your nearest FLOWSERVE location.

3 LOGIX 510si OVERVIEW

The Logix 510si is a two-wire, 4-20 mA input digital valve positioner. The Logix 510si positioner controls single-acting actuators with linear and rotary mountings. The Logix 510si is completely powered by the 4-20 mA input signal. The minimum input signal required to function is 3,6 mA.

Since the positioner is insensitive to supply pressure changes and can handle supply pressures from 1,5 to 6 barg (22 to 87 psig), a supply regulator is usually not required; however, in applications where the supply pressure is higher than the maximum actua-

tor pressure rating a supply regulator is required to lower the pressure to the actuator's maximum rating (not to be confused with operating range). A coalescing air filter is recommended for all applications due to the close tolerances in the positioner. Optional analog feedback system as well as limit switch unit and a directly attachable double acting module complete the Logix 510si positioner accessories.



NOTE: *The air supply must conform to ISA 7.0.01 or IEC 770 (a dew point at least 10 °C / 18 °F below ambient temperature, particle size below five microns – one micron recommended – and oil content not to exceed one part per million).*

4 SPECIFICATIONS

Table 1: Input Signal

Input Signal Range	4 - 20 mA
Compliance Voltage	6,0 VDC (analog)
Voltage Supply (maximum)	30 VDC
Minimum Required Operating Current	3,6 mA

Table 2: Stroke Output

Feedback Shaft Rotation	0° to 90° normal 0° to 40° minimum
-------------------------	---------------------------------------

Table 3: Supply Air

Supply Air Quality	Free from moisture, oil and dust per IEC 770 and ISA-7.0.01
Input Pressure Range	1,5 to 6,0 bar (22 – 87 psi)
Air Consumption (steady state)	0,08 Nm ³ /h @ 1,5 bar 0,047 SCFM @ 22 psi 0,120 Nm ³ /h @ 6,0 bar 0,071 SCFM @ 87 psi

Table 4: Output Signal

Output Pressure Range	0 - 100 % of supply air pressure
Output Flow Capacity (input @ pressure)	2,4 Nm ³ /h @ 1,5 bar 1,41 SCFM @ 22 psi 7,0 Nm ³ /h @ 6,0 bar 4,12 SCFM @ 90 psi

Table 5: Performance Characteristics (typical)

Linearity	< ± 1,0%
Resolution	< 0,3%
Repeatability	< 0,5%
Deadband	< 0,5%

Table 6: Environmental Conditions

Operating Temperature	Standard	-20 – 80 °C -4 – 178 °F
	Low	-40 – 80 °C -40 – 178 °F
Transport and Storage Temperature		-40 – 80 °C -40 – 178 °F
Operating Humidity		0 – 100% non-condensing
Intrinsic Safety		Logix 510 - 04 ATEX II 1G EEX ia II C T6

Table 7: Physical Specifications

Housing Material	Cast aluminum, powder-painted
Soft Goods	Nitrile
Weight	1,2 kg (2,7 lbs)

Table 8: Shipping weights

Shipping weights (incl. mounting kit)	Specification	Logix 510
	with pressure gauges	1,6 kg
	without pressure gauges	1,2 kg

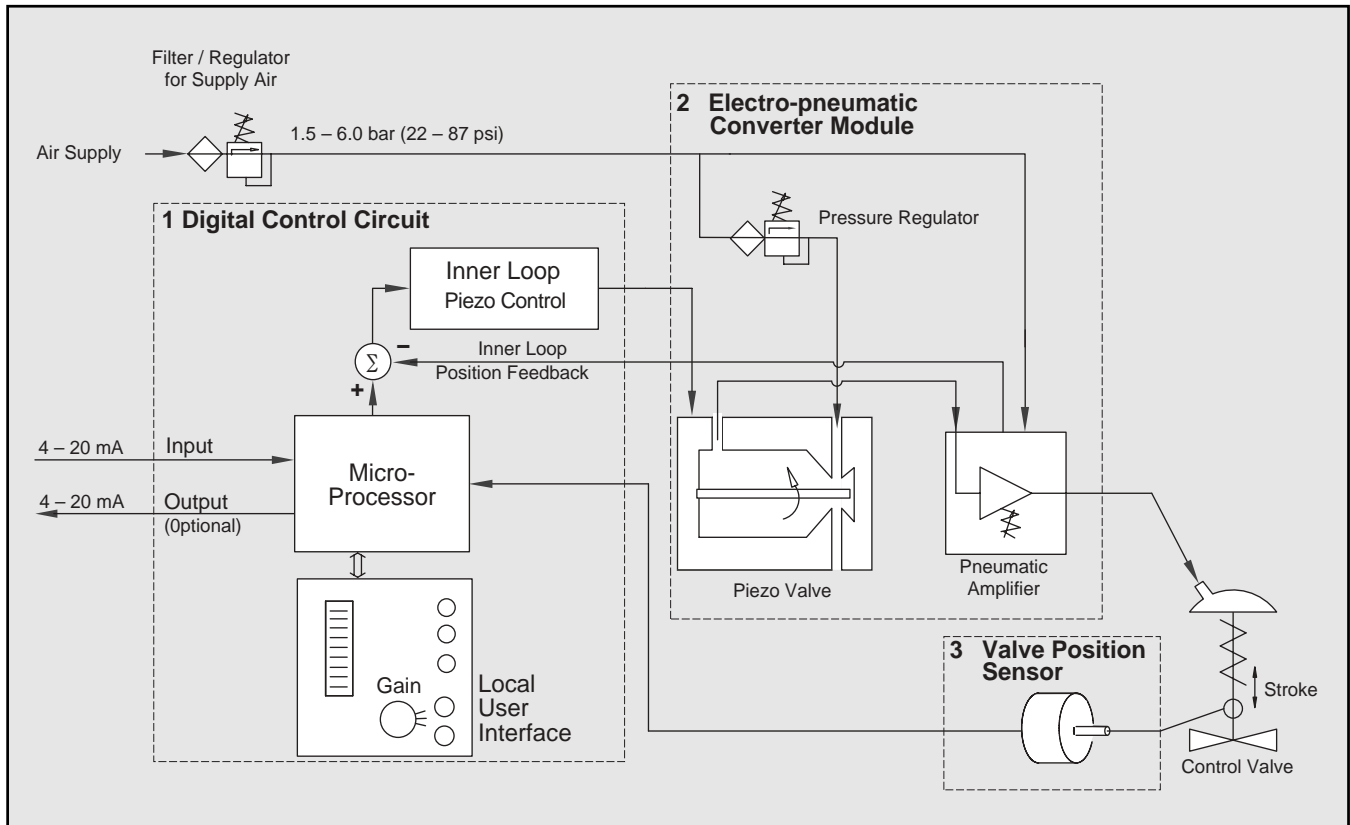

Figure 1: Logix 510si Principle of Operation

5 PRINCIPLE OF OPERATION

The Logix 510si positioner is a digital positioner with various options. The positioner consists of three main modules:

1. The microprocessor-based electronic control module includes direct local user interface switches
2. The piezo valve-based electro-pneumatic converter module
3. The infinite resolution valve position sensor.

The basic positioner operation is best understood by referring to Figure 1. The complete control circuit is powered by the two-wire, 4-20 mA command signal. The analog 4-20 mA command is passed to the microprocessor, where it is compared to the measured valve stem position. The control algorithm in the processor performs control calculations and produces an output command to the piezo valve, which drives the pneumatic amplifier. The position of the pilot valve in the pneumatic amplifier is measured and relayed to the inner loop control circuit. This two-stage control provides for more responsive and tighter control than is possible with a single stage control algorithm. The pneumatic amplifier controls the airflow to the actuator. The change of pressure and volume of the air in the actuator causes the valve to stroke. As the valve ap

6 TUBING POSITIONER TO ACTUATOR

After mounting has been completed, tube the positioner to the actuator using the appropriate compression fitting connectors:

Air connections: 1/4" NPT (standard air connection)

Auxiliary power: Pressurized air or permissible gases, free of moisture and dust in according with IEC 770 or ISA 7.0.01.

Pressure range: 1,5 – 6,0 bar (22 – 87 psi)

For connecting the air piping, the following notes should be observed:

1. The positioner passageways are equipped with filters, which remove medium and coarse size dirt from the pressurized air. If necessary, they are easily accessible for cleaning.
2. Supply air should meet IEC 770 or ISA 7.0.01 requirements. A coalescing filter should be installed in front of the supply air connection Z. Now connect the air supply to the filter, which is connected to the Logix 500 Series positioner.
3. With a maximum supply pressure of 6 bar (87 psi) a regulator is not required.
4. With an operating pressure of more than 6 bar (87 psi), a reducing regulator is required. The flow capacity of the regulator must be larger than the air consumption of the positioner (7 Nm³/h @ 6 bar / 4,12 scfm @ 87 psi).

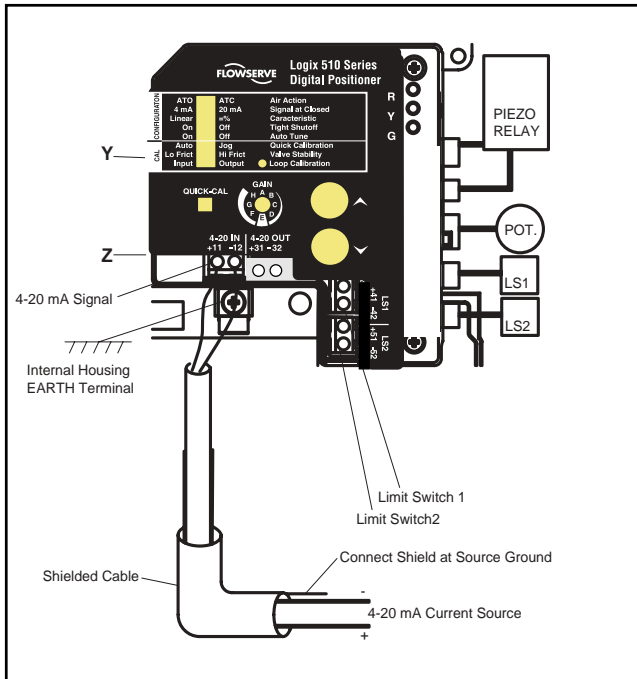

Figure 2: Wiring Diagram

5. Connect the outlet connector Y of the positioner to the actuator with tubing, independent of the action (direct or reverse).

7 WIRING AND GROUNDING GUIDELINES

Electrical connections: signal cable with cable passage (NPT, PG13,5, or M20 x 1,5) to terminals 2 x 2,5 mm

Input signal: 4 – 20 mA

NOTE: Observe the minimum requirements of voltage and equivalent electrical load: 6,0 VDC / 300 Ω / at 20 mA

The performance is ensured only for a minimum input current of 3,6 mA.

For wiring, the following notes should be observed:

NOTE: The input loop current signal to the Logix 510si should be in shielded cable. Shields must be tied to a ground at only one end of the cable to provide a place for environmental electrical noise to be removed from the cable. In general, shield wire should be connected at the source. (Figure 8)

Connect the 4-20 mA current source to terminals +11 and -12 (Figure 8).

Grounding Screw

The grounding screw, located inside the positioner cover, should be used to provide the unit with an adequate and reliable earth ground reference. This ground should be tied to the same ground as the electrical conduit. Additionally, the electrical conduit should be earth grounded at both ends of its run. The grounded screw must not be used to terminate signal shield wires.

Table 9: Connection Table

Connection	Description
+11	Input+ 4..20 mA
-12	Input- 4..20 mA
+31 *	Output+ 4..20 mA
-31 *	Output- 4..20 mA
+41 *	Limit switch 1+
-42 *	Limit switch 1-
+51 *	Limit switch 2+
-52 *	Limit switch 2-
Y	Pneumatic output signal (outlet)
Z	Air supply

* Optional

Compliance Voltage (Figure 9)

Output compliance voltage refers to the voltage limit the current source can provide. A current loop system consists of the current source, wiring resistance, barrier resistance (if present), and the Logix 510 impedance. The Logix 510 requires that the current loop system allow for a 6,0 VDC drop across the positioner at maximum loop current.

CAUTION: Never connect a voltage source directly across the positioner terminals. This could cause permanent circuit board damage.

In order to determine if the loop will support the Logix 510, perform the following calculation:

$$\text{Voltage} = \text{Compliance Voltage (@Current}_{\text{MAX}}) - \text{Current}_{\text{MAX}} * (R_{\text{barrier}} + R_{\text{wire}})$$

The calculated voltage must be greater than 6.0 VDC in order to support the Logix 510.

Example: DCS Compliance Voltage = 19 V

$$R_{\text{barrier}} = 300 \Omega$$

$$R_{\text{wire}} = 25 \Omega$$

$$\text{CURRENT}_{\text{MAX}} = 20 \text{ mA}$$

$$\text{Voltage} = 19 \text{ V} - 0,020 \text{ A} * (300 \Omega + 25 \Omega) = 12,5 \text{ V}$$

The voltage 12,5 V is greater than the required 6.0 V; therefore, this system will support the Logix 510si. The Logix 510si has an input resistance equivalent to 300 Ω at a 20 mA input current.

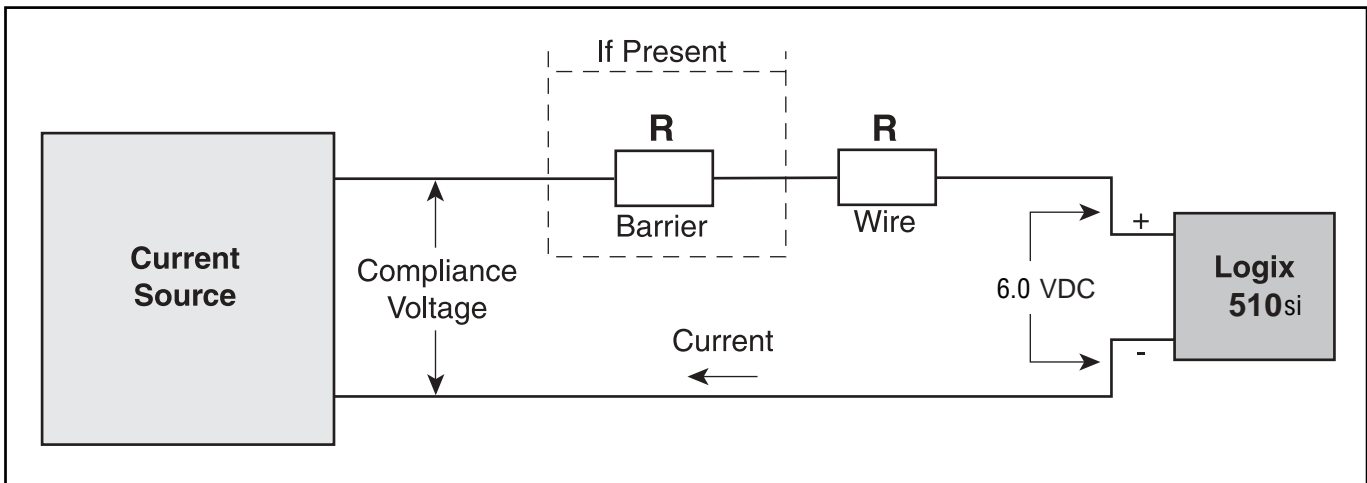

Figure 3: Compliance Voltage

Electromagnetic Compatibility

The Logix 510si digital positioner has been designed to operate correctly in electromagnetic (EM) fields found in typical industrial environments. Care should be taken to prevent the positioner from being used in environments with excessively high EM field strengths (greater than 10 V/m). Portable EM devices such as hand-held two-way radios should not be used within 30 cm of the device.

Ensure proper wiring and shielding techniques of the control lines, and route control lines away from electromagnetic sources that may cause unwanted noise. An electromagnetic line filter can be used to further eliminate noise (FLOWERVE Part Number 10156843).

In the event of a severe electrostatic discharge near the positioner, the device should be inspected to ensure correct operability. It may be necessary to recalibrate the Logix 510si positioner to restore operation.

8 STARTUP

8.1 Logix 510si Local Interface Operation

The Logix 510si local user interface allows the user to fully configure the operation of the positioner, tune the response, and calibrate the positioner. The Local interface consists of a quick calibration button for automatic zero and span setting, along with two jog buttons for manually spanning the positioner, or for local Jogging of the valve. There is also a switch block containing 8 switches. Five of the switches are for basic configuration settings, three are for calibration options. There is also a rotary selector switch for adjusting the positioner gain settings. A 4-20 current loop calibration button is accessed through a hole in the cover next to the bottom dipswitch. For indication of the operational status or alarm conditions there are 3 LEDs on the local user interface. This document describes the setting and use of the Logix 510si user interface.

8.2 Initial DIP Switch Setting

Before placing the unit in service, set the dipswitches in the Configuration and Cal boxes to the desired control options. For a detailed description of each dipswitch setting, see sections 1&2.



NOTE: The switch settings in the Configuration box are activated **only** by pressing the Quick-Cal button. **Operation of Configuration Dipswitch Setup** -The first 5 Dip Switches are for basic configuration.

- a. **Air Action** - This must be set to match the configuration of the valve/actuator mechanical tubing connection and spring location since these determine the air action of the system.
 - **ATO** (air-to-open)- Selecting **ATO** if increasing output pressure from the positioner is tubed so it will cause the valve to **open**.
 - **ATC** (air-to-close)- Selecting **ATC** if increasing output pressure from the positioner is tubed so it will cause the valve to **close**.
- b. **Signal at Closed** - Normally this will be set to **4 mA for an Air-to-open actuator, and 20 mA for an Air-to-close actuator configuration**.
 - Selecting **4 mA** will make the valve fully **closed** when the signal is 4mA and fully **open** when the signal is 20 mA.
 - Selecting **20 mA** will make the valve fully **closed** when the signal is 20 mA and fully **open** when the signal is 4 mA.
- c. **Characteristic**
 - Select **Linear** if the actuator position should be directly proportional to the input signal.
 - The =% option will characterize the actuator response to the input signal based on a standard 30:1 equal percent rangability curve.
- d. **Tight Shutoff**
 - Select **On** to have the positioner fully saturate the actuator closed at a signal less than 1%.
 - Setting the switch in the **Off** position disables this feature.
- e. **Auto Tune** -This switch controls whether the positioner will auto tune itself every time the quick cal button is pressed

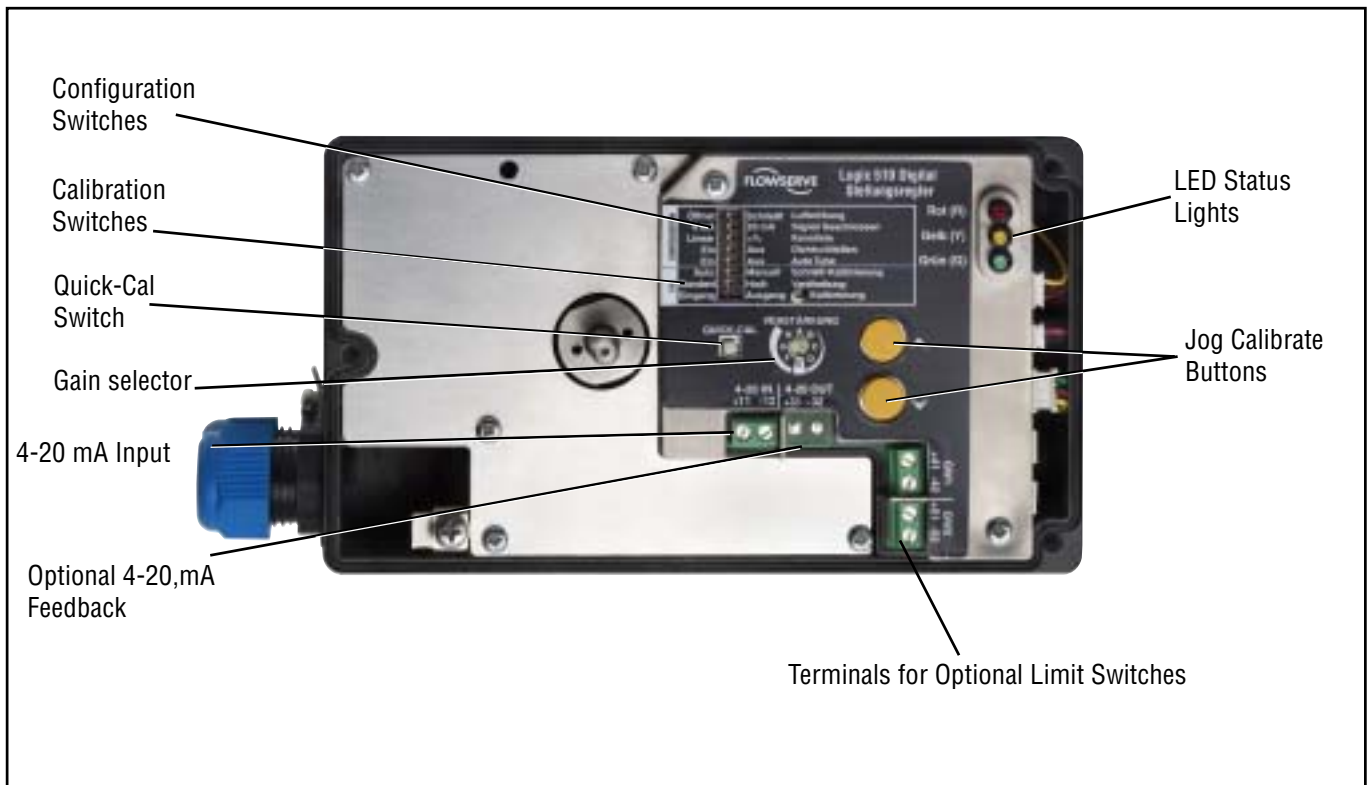

Figure 4: Logix 510si Local Interface

- **On** enables an automatic tuning feature that will automatically determine the positioner gain settings every time a “Quick-Cal” is performed. The gain settings can be modified after a calibration by adjusting the rotary “Gain” switch.

! **Note:** *there is a small black arrow indicating the selection. The slot does not indicate the chosen gain.*

- If the rotary “Gain” selector switch is set to “E” with the auto tune switch **on**, a Flowserve standard response tuning set will be calculated and used.
- If the rotary “Gain” selector switch is set to “D”, “C”, “B”, or “A” with the auto tune switch **on**, progressively lower gain settings will be calculated and used.
- If the rotary “Gain” selector switch is set to “F”, “G”, or “H” with the auto tune switch **on**, progressively higher gain settings will be calculated and used.
- **Off** forces the positioner to use one of the factory preset tuning sets determined by the rotary “Gain” selector switch. Settings “A” through “H” are progressively higher gain pre defined tuning sets.

8.3 Setup of the Cal Dipswitches - The last 3 Dip Switches are for calibration configuration.

a. Quick calibration operating mode.

- Select **Auto** if the valve/actuator assembly has an internal stop in the open and closed positions. In **Auto** mode the positioner will fully

close the valve and register the 0% position and then **open** the valve to the stop to register the 100% position when performing a self-calibration. See detailed instructions in section 10.4 on how to perform an auto positioner calibration.

- Select **Jog** if the valve/actuator assembly has no calibration stop in the open position and or if you want to manually set the closed position. In the **Jog** mode the positioner waits for the user to set the open and closed positions using the Jog buttons labeled with the Δ and ∇ arrows. See the detailed instructions in section 10.4 on how to perform a manual calibration using the “Jog” buttons.

b. Stability Switch – This switch adjusts the position control algorithm of the positioner for use with low friction control valves or high friction automated valves.

- Placing the switch to the left optimizes the response for low friction, high performance control valves. This setting provides for optimum response times when used with most low friction control valves.
- Placing the switch to the right optimizes the response for valves and actuators with high friction levels. This setting slightly slows the response and will normally stop limit cycling that can occur on high friction valves.

WARNING: During the Quick-Cal operation the valve may stroke unexpectedly. Notify proper personnel that the valve will stroke, and make sure the valve is properly isolated.

c. **Loop Calibration- this setting determines whether the input or output is calibrated when a loop calibration is initialized.**

- An **Input** loop calibration, requiring an external current source, will be started when the Loop calibration button is pressed with a small object with the switch in the **Input** position. See the detailed instructions in section 8.7.1 on how to perform an **Input** calibration using the Loop calibration button.
- An **Output** (optional) loop calibration, requiring an external current meter and power source, will be started when the Loop calibration button is pressed with a small object with the switch in the **Output** position. See the detailed instructions in section 8.7.2 on how to perform an **Output** calibration using the Loop calibration button.



WARNING: During the Quick-Cal operation the valve may stroke unexpectedly. Notify proper personnel that the valve will stroke, and make sure the valve is properly isolated.

8.4 QUICK-CAL Operation

The QUICK-CAL button is used to locally initiate a calibration of the positioner. Pressing and holding the QUICK-CAL button for approximately 3 seconds will initiate the calibration. The settings of all the configuration switches are read and the operation of the positioner adjusted accordingly. A QUICK-CAL can be aborted at any time by briefly pressing the QUICK-CAL button and the previous settings will be retained. If the Quick calibration switch (be careful not to confuse with the QUICK-CAL button) is set to Auto and the valve/actuator assembly has the necessary internal stops the calibration will complete automatically. While the calibration is in progress you will notice a series of different lights flashing indicating the calibration progress. When the lights return to a sequence that starts with a green light the calibration is complete. (see the appendix for an explanation of the various light sequences)



WARNING: When operating using local control of the valve, the valve will not respond to external commands. Notify proper personnel that the valve will not respond to remote command changes, and make sure the valve is properly isolated.

If the Quick calibration switch is set to Jog, the LED's will initially flash in a sequence of Y-R-R-G (yellow-red-red-green) which indicates that the user must use the jog keys to manually position the valve to 100%. When the valve is approximately at the position desired for 100% open, press both the Δ and ∇ buttons simultaneously to proceed to the next step. (Note

that the Logix 510si is only setting internal gain and direction of rotation parameters at this point the actual span is set after the zero is set.) The valve will then moved closed and flash a Y-G-G-R sequence, allowing the user to adjust the valve position to 0% using the jog buttons. When the stem is properly positioned press both the Δ and ∇ buttons simultaneously again to register the 0% position and to proceed. The valve will then stroke back to the 100% open position and the calibration the LED's will flash in a sequence of Y-R-R-G again and wait for the user to make final adjustments. When the 100% is correct press both the Δ and ∇ buttons simultaneously to continue. No more user actions are required while the calibration process automatically finishes. When the lights return to a sequence that starts with a green light the calibration is complete. (see the appendix for an explanation of the various light sequences)

Note: It is recommended that the first time a Logix 510si is installed on a new actuator that a second QUICK-CAL be performed.



WARNING: When operating using local control of the valve, the valve will not respond to external commands. Notify proper personnel that the valve will not respond to remote command changes, and make sure the valve is properly isolated.

8.5 Local control of valve position-Can be done from the user interface by holding both jog buttons while then simultaneously pressing the quick cal button for 3 seconds. When in this mode the position can be adjusted using the Δ and ∇ buttons. While in this mode the LED's will flash a YGRR (yellow-green-red-red) sequence. To exit the local control mode and return to normal operation, briefly press the quick-Cal button.

8.6 Factory reset - Hold Quick cal button while applying power and all of the internal variables including calibration will be reset to factory defaults. The positioner must be re-calibrated after a factory reset.

8.7 Loop Calibration - Using a small pointed object push and hold, the Loop Calibration button through the small hole on the electronic cover for 3 seconds to initiate calibration of either the 4-20 mA input or output current loop as selected by the bottom Dip switch.

8.7.1 Input loop calibration - Note that the valve will be locked at its position when an input loop calibration is initiated until the calibration is completed. If a loop calibration is started with the **Input** loop selected on the Loop calibration Dip switch, the LED's will flash a sequence of Y-G-G-Y indicating that it is waiting for the minimum signal to be input to the positioner on terminals +11 and -12 from an external 4-20 mA current source. Normally this will be 4 mA, but if split range operation is required use the minimum current for the desired operating range. When the minimum signal value is set at the desired value, press the Δ and ∇ buttons simultaneously to proceed to the next step. The LED's will now flash a sequence of Y-G-Y-R

indicating that it is waiting for the maximum signal to be input to the positioner. Normally this will be 20 mA, but if split range operation is required use the maximum current for the desired range. When the maximum signal value set at the desired value, press the Δ and ∇ buttons simultaneously to set the span. The LED's then will flash a sequence of Y-Y-G-G indicating that the calibration is complete. The signal can now be adjusted to the desired output value without affecting the valve position. Press the Δ and ∇ buttons simultaneously to put the unit back in operation. Note that the input calibration correlates the signal to 0% and 100% signal it does not affect the position calibration all since that calibration is done separately with the Quick-Cal button.

8.7.2 Output loop calibration (optional) - If a loop calibration is started with the **Output** loop selected on the Loop calibration Dip switch, the LED's will flash a sequence of Y-G-G-G indicating that it is waiting for the 0% signal to be adjusted using the Δ and ∇ buttons for the output current loop on positioner on terminals +31 and -32. (Note that the loop must be externally powered with a voltage between 12VDC and 40VDC and a current meter used to measure the current in the loop). Normally this will be 4 mA, but if split range operation is required adjust to the minimum current for the desired range. When the 0% signal value is set at the desired value, press the Δ and ∇ buttons simultaneously to proceed to the next step. The LED's will now flash a sequence of Y-R-G-Y indicating that it is waiting for the 100% signal to be adjusted using the Δ and ∇ buttons for the output current loop. Normally the 100% setting will be 20 mA, but if split range operation is required adjust to the maximum current for the desired range. When the 100% signal value set at the desired value press the Δ and ∇ buttons simultaneously to complete the calibration.

9 STATUS CODES

Logix 510si Status Condition Codes		
Colors	Identifier	Indication and resolution
G - - -		Any sequence starting with a Green light flashing first is a normal operating mode and indicates that there are no internal problems.
GGGG	1	No errors , alerts, or warnings.
GGGY	2	MPC active - The command is below the 1% command limit for tight shutoff feature. This is a normal condition for a closed valve. To clear the condition, adjust the command signal above the specified MPC value, or disable the feature by moving the Tight Shutoff switch to the off position and recalibrating.
GGYR	3	LED test mode, Initializing - This sequence should only be visible for 3 sequences when powering up the unit.

Logix 510si Status Condition Codes

Colors	Identifier	Indication and resolution
Y	---	Any sequence starting with a yellow light indicates that the unit is in a special calibration or test mode, or that there was a calibration problem.
YY	4	Command minimum saturated - Calibration error indicating that the 4-20 mA signal corresponding to the minimum command was too low. Adjust the signal to higher range and re-do the calibration. This error may be cleared by briefly pushing the quick-cal button, which will force the positioner to use the parameters from the last good calibration.
YY	5	Command span - Calibration error indicating that the 4-20 mA signal was below the minimum calibration span. The minimum calibration span is 3.0 mA. This error may be cleared by briefly pushing the quick-cal button, which will force the positioner to use the parameters from the last good calibration or if the Δ and ∇ buttons are pressed simultaneously the calibrated span will be used even though it is less than the recommended range.
YY	6	Command maximum saturated - Calibration error indicating that the 4-20 mA signal corresponding the maximum command was too high. Adjust the signal a lower range and re-do the calibration. This error may be cleared by briefly pushing the quick-cal button, which will force the positioner to use the parameters from the last good calibration.
YY	7	Calibration complete - Indicates that a 4-20 command calibration is complete. This pause allows the signal to be adjusted without affecting the valve position. Press the Δ and ∇ buttons simultaneously to put the unit back in operation.
YR	8	Feedback span - The range of motion of the position feedback arm was too small. Check for loose linkages and/or adjust the feedback pin to a position closer to the follower arm pivot to create a larger angle of rotation. Also check the air supply to make sure the system is properly connected. This error may be cleared by briefly pushing the quick-cal button, which will force the positioner to use the parameters from the last good calibration or if the Δ and ∇ buttons are pressed simultaneously the calibrated span will be used even though it is less than the recommended range.
YR	9	Feedback 100 saturated - Calibration error indicating that the position sensor was out of range during the calibration. To correct the condition, adjust the positioner mounting, linkage or feedback potentiometer to move the position sensor back into range then restart the calibration. This error may be cleared by briefly pushing the quick-cal button, which will force the positioner to use the parameters from the last good calibration.
YR	10	Waiting for 100% position JOG set point from User - only used during Jog calibration see explanation in Quick-Cal section of main document for operation.
YR	11	Feedback no-motion during calibration - Indicates that there was no motion of the actuator based on the current stroke time configuration. Check linkages and air supply to make sure the system is properly connected. If the time out occurred because the actuator is very large then simply retry the Quick cal and the positioner will automatically adjust for a larger actuator by doubling the time allowed for movement. This error may be cleared by briefly pushing the quick-cal button, which will force the positioner to use the parameters from the last good calibration.
YR	12	Setting IL offset (during Stroke calibration) - An automatic step in the calibration process that is done with the valve a 50% position. This must be completed for proper operation.
YR	13	Feedback 0 saturated - Calibration error indicating that the position sensor was out of range during the calibration. To correct the condition, adjust the positioner mounting, linkage or feedback potentiometer to move the position sensor back into range then restart the calibration. This error may be cleared by briefly pushing the quick-cal button, which will force the positioner to use the parameters from the last good calibration.
YR	14	Stroke Calibration in Progress - Calibration sequence started using the local Quick- Cal button. It may be cancelled by briefly pushing the quick-cal button.
YR	15	Unable to set IL offset during QUICK-CAL – This may occur on very large or small actuators on the first calibration attempt. The Logix 510 will automatically adjust parameters for future calibrations. To Continue briefly push the quick-cal button to acknowledge and restart Quick-Cal.
YR	16	Feedback unstable during calibration - Check for loose linkages or loose positioner sensor. This error may be cleared by briefly pushing the quick-cal button, which will force the positioner to use the parameters from the last good calibration.
YG	17	4-20 mA output 0% - Waiting for the user to adjust the 0% 4-20 mA output during calibration.
YG	18	4-20 mA input 0% - Waiting for 0% 4-20 mA command input during command calibration.
YG	19	Jog 0% - Waiting for 0% position JOG set point from User - only used during Jog calibration see explanation in Quick-Cal section of main document for operation
YG	20	4-20 mA output 100% - Waiting for the user to adjust the 100% 4-20 mA output during calibration.
YG	21	4-20 mA input 100% - Waiting for 100% 4-20 mA command input during command calibration.
YGR	22	Analog output span too small - The span must be calibrated to a range greater than 3.0 mA. This error may be cleared by briefly pushing the quick-cal button, which will force the positioner to use the parameters from the last good calibration or if the Δ and ∇ buttons are pressed simultaneously the calibrated span will be used even though it is less than the recommended range.
YGR	23	JOG Control Mode - the unit has been placed in a local override mode where the valve can only be stroked using the two local jog buttons. It may be cancelled by briefly pushing the quick-cal button.

Logix 510si Status Condition Codes

Colors	Identifier	Indication and resolution
R - - -		Any sequence starting with a red light indicates that there is an operational problem with the unit.
RRYY	24	Bad electronic assembly - replace.
RGRR	25	Position Deviation – Indicates that the position has exceeded a fixed 20% error between command and position for a period of time 5 times longer than the recorded stroke time. This error is usually seen when the positioner is first mounted and powered up before a stroke calibration has been done. If the positioner is properly calibrated, the air supply is correct, and the linkage is properly adjusted this error normally indicates that there is a mechanical problem in the positioner, actuator, or valve that is preventing the valve from stroking properly. If a regulated air supply connected to the actuator properly strokes the valve this indicates a bad positioner and should be replaced if a calibration does not clear the error.

10 Version number checking- The version number of the embedded code may be checked at any time except during a calibration by holding down the Δ button. This will not alter the operation of the unit other than to change the blink sequence to 3 blinks indicating the major version number. Holding the ∇ button will give the minor version number without affecting operation. The version codes are interpreted by adding up the numbers assigned according to the following table:

Color	First blink value	Second blink value	Third blink value
Green	0	0	0
Yellow	9	3	1
Red	18	6	2

For example if holding the Δ button gave a G-G-R code, and holding the ∇ button gave a Y-Y-G code then the resulting version number would be $(0+0+2).(9+3+0)$ or version 2.12.

11 TROUBLE SHOOTING

Troubleshooting Logix 510si Digital Positioners		
Failure	Probable Cause	Corrective action
No LED is blinking	<ol style="list-style-type: none"> 1. Current source below 3.6 mA 2. Incorrect wiring polarity 	<ol style="list-style-type: none"> 1. Verify current source is outputting at least 3,6 mA 2. Check wiring for correct polarity
Unit does not respond to analog commands	<ol style="list-style-type: none"> 1. Error occurred during calibration 	<ol style="list-style-type: none"> 1. Correct calibration error. Recalibrate
Valve position reading is not what is expected	<ol style="list-style-type: none"> 1. Stroke not calibrated 2. Stem position sensor mounting is off 180 degrees 	<ol style="list-style-type: none"> 1. Recalibrate 2. Orient sensor properly
Position is driven fully open or closed and will not respond to command	<ol style="list-style-type: none"> 1. Stroke not calibrated 2. Inner-loop hall sensor not connected 3. Wrong air action set on DIP switch 4. Actuator tubing backward 5. Electro-pneumatic converter malfunctioning 	<ol style="list-style-type: none"> 1. Calibrate valve stroke 2. Verify hardware connections 3. Check ATO (Air-to-open) and ATC (Air-to-Close) settings. Recalibrate 4. Verify ATO/ATC actuator tubing 5. Replace electro-pneumatic converter
Sticking or hunting operation of the positioner	<ol style="list-style-type: none"> 1. Contamination of the electro-pneumatic converter. 2. Control tuning parameters not 	<ol style="list-style-type: none"> 1. Check air supply for proper filtering and meeting ISA specifications ISA-7.0.01 2. Lower gain switch settings

12 SPARE PART KITS

Item No.	Description	Part-No.
1	Cover Assembly Yellow White Black	
2a	PC Board Assembly	H10114000
2b	PC Board Assembly with analog feedback	H10114001
3	Repair kit for Logix 500-Relay Module Assembly	H10011500
4	Repair kit for Potentiometer Assembly	H10011600
5	Position Feedback Assembly	H194500003
8	Follower Arm Assembly Max. stroke 65 mm Max. stroke 110 mm	H194512001 H194512002

Mounting Kits

Item No.	Description	Part-No.
–	IEC 534 part 6 (Valtek 2000, Kämmer KA, Kämmer KP, and standard NAMUR linear valves)	H192685001
–	Rotary VDI/VDE 3845 (DIN ISO 5211)	H194984001

Gauge Kits

Item No.	Description	Part-No.
–	2 gauge set, 6 bar / 4 bar, brass, nickel plated	H179379013
–	2 gauge set, 6 bar / 4 bar, stainless steel	H179379015

Regional Headquarters**Flowserve**

Manderscheidstr. 19
45141 Essen
Germany
Telephone: +49 (0) 201 8919 5
Facsimile: +49 (0) 201 8919 662

Flowserve

1350 N. Mt. Springs Prkwy.
Springville, UT 84663
USA
Telephone: +1 801 489 8611
Facsimile: +1 801 489 3719

Flowserve

12 Tuas Avenue 20
Republic of Singapore 638824
Telephone: +65 862 3332
Facsimile: +65 862 4940

Main Sales Offices (Europe, Middle East, Africa)**Flowserve**

von-Braun-Straße 19a
48681 Ahaus
Germany
Telephone: +49 (0) 2561 6860
Facsimile: +49 (0) 2561 68648

Flowserve

12, av. du Québec
91965, Courtaboeuf Cedex
France
Telephone: +33 (0) 1 60 923 251
Facsimile: +33 (0) 1 60 923 299

Flowserve

Station Road
Pershore, Worcestershire
England WR102BZ
Telephone: +44 (0) 1386 55 45 51
Facsimile: +44 (0) 1386 55 49 68

Flowserve

Allee du Quartz 1
CH-2300 La-Chaux-de Fonds
Switzerland
Telephone: +41 (0) 32 925 9700
Facsimile: +41 (0) 32 926 5422

Flowserve

Units 1 and 2
26, Imvuba Road, Sebenza Ext 6
Edenvale, Gauteng
Edenglen 1613
South Africa
Telephone: +27 11 609 2094
Facsimile: +27 11 609 3735

Flowserve

C/O Saleh & Abdulaziz Abahsain
P.O. Box 209
Al Khobar 31952
Saudi Arabia
Telephone: 9663 857 3442
Facsimile: 9663 859 5284