

Register 14 CONTENTS - ARL

Contents	Page
<i>Technical Data ARL-DIN</i>	2
<i>Technical Data ARL-ANSI</i>	3
<i>Material Specification ARL</i>	4
<i>Dimensions ARL-DIN</i>	5
<i>Dimensions ARL-ANSI</i>	6
<i>Spare Parts ARL</i>	7
<i>Assembly Instructions ARL</i>	8
<i>Disassembly Instructions ARL</i>	8
<i>ARL - Recommended Tightening Torques</i>	9
<i>ARL - K_v and C_v - Data</i>	9

Technical Data ARL

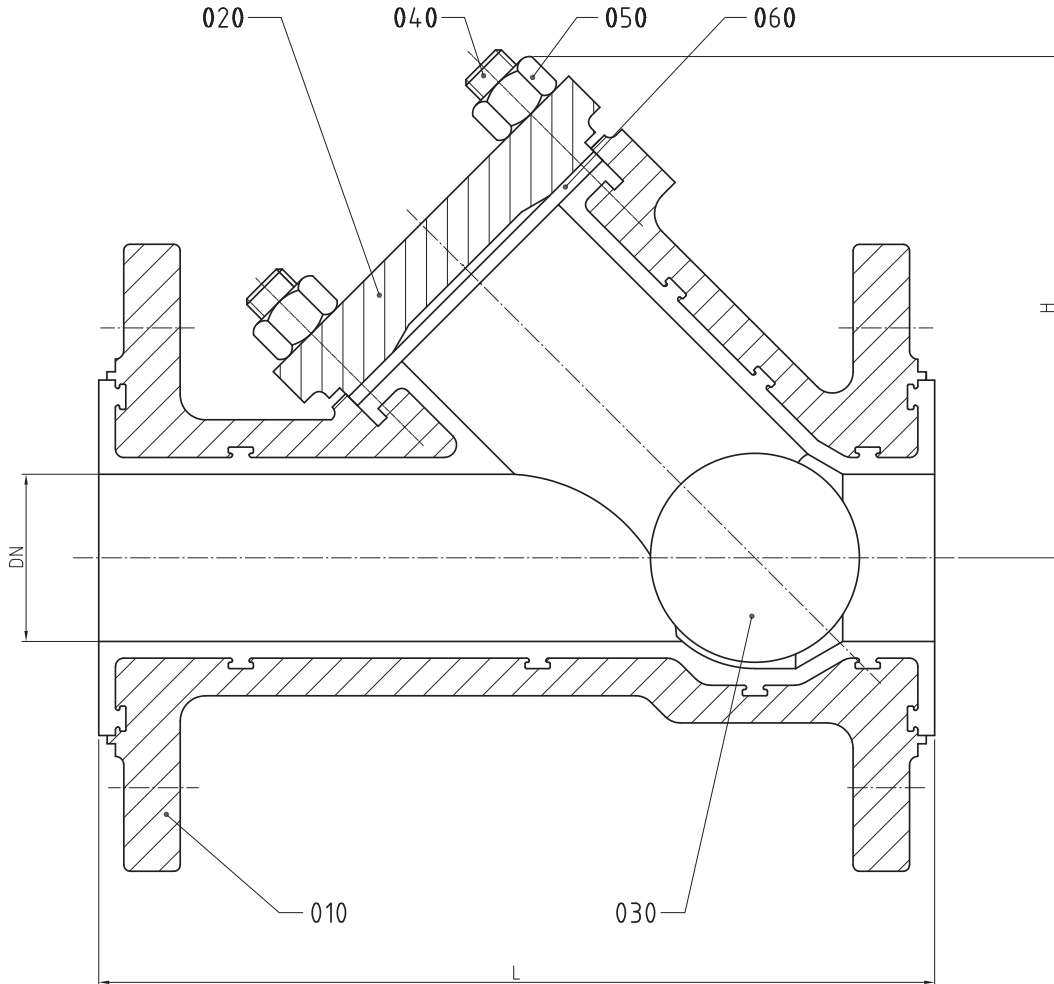

DN / DIN		L	H	weight	
025	mm	160	90	kg	4,8
	inch	6,3	3,54	lbs	10,6
040	mm	200	120	kg	9,2
	inch	7,87	4,72	lbs	20,3
050	mm	230	136	kg	12,2
	inch	9,06	5,35	lbs	26,8
080	mm	310	206	kg	20,5
	inch	12,2	8,11	lbs	45,2

Face-to-Face Dimension: DIN EN 558 (Basic series 1)
 Flange Connection: DIN EN 1092 - 2 (PN 16)
 Tightness test: DIN EN 12266-1 (leak rate B)

Technical Data ARL

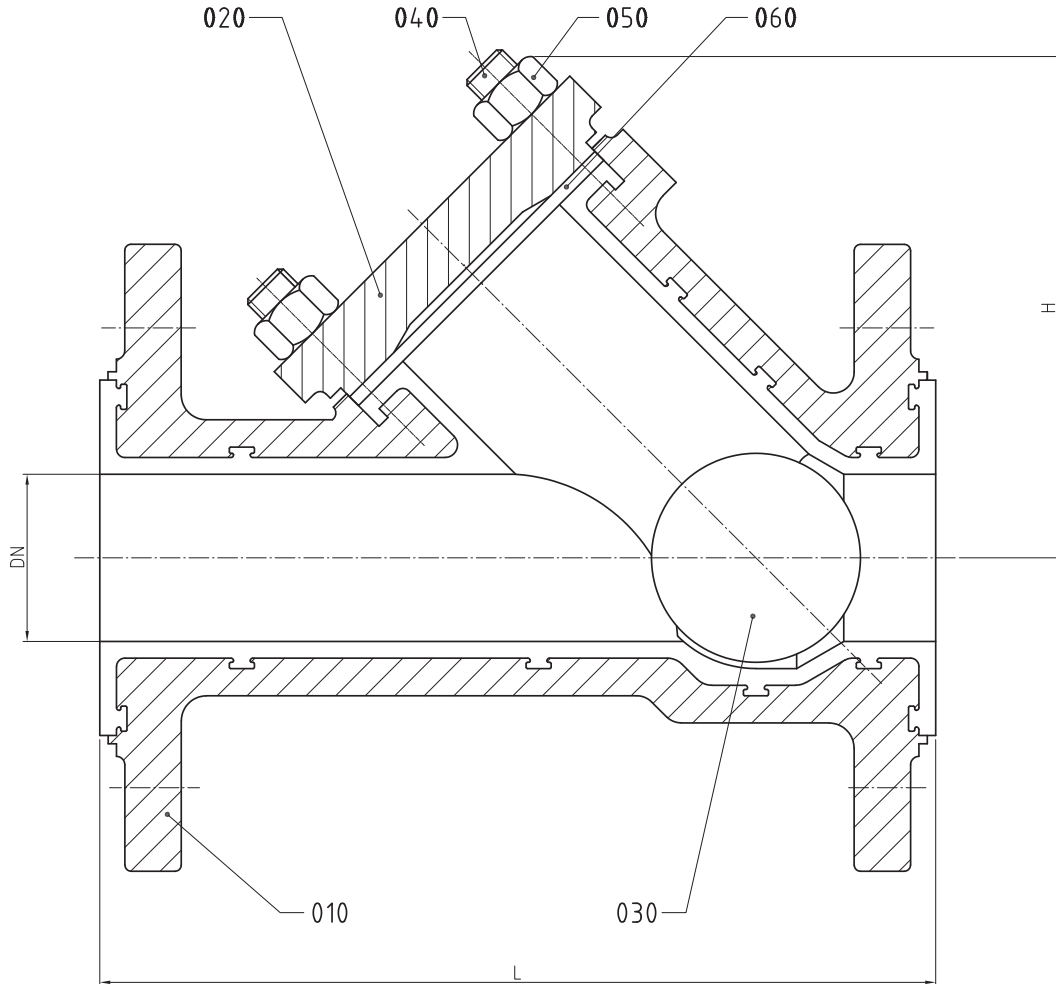

DN / ANSI		L	H	weight	
1"	mm	160	90	kg	4,8
	inch	6,3	3,54	lbs	10,6
1½"	mm	200	126	kg	9,2
	inch	7,87	4,96	lbs	20,3
2"	mm	230	136	kg	12,2
	inch	9,06	5,35	lbs	26,8
3"	mm	310	206	kg	20,5
	inch	12,2	8,11	lbs	45,2

Face-to-Face Dimension: DIN EN 558 (Basic series 1)
 Flange Connection: ANSI B 16.5 - 150 lbs
 Tightness test: DIN EN 12266-1 (leak rate B)

Material specification ARL

No.	Designation	Pieces	Material	Material-No. / DIN	ASTM / AISI
010	body	1	ductile iron / PFA ° ductile iron / FEP °	EN-JS1049 (GGG-40.3) / DIN EN 1563	A 395
020	bonnet	1	ductile iron	GGG-40.3 / DIN EN 1563 DIN EN 1563	A 395
030	ball	1	PTFE - solid ball	pure - PTFE	
040	stud bolt	4	stainless steel	1.4301 / DIN EN 10088-3	A 193 B8
050	hexagon nut	4	stainless steel	1.4301 / DIN EN 10088-3	A 193 B8
060	flut gasket	1	PTFE		

° *optional*

Dimensions ARL

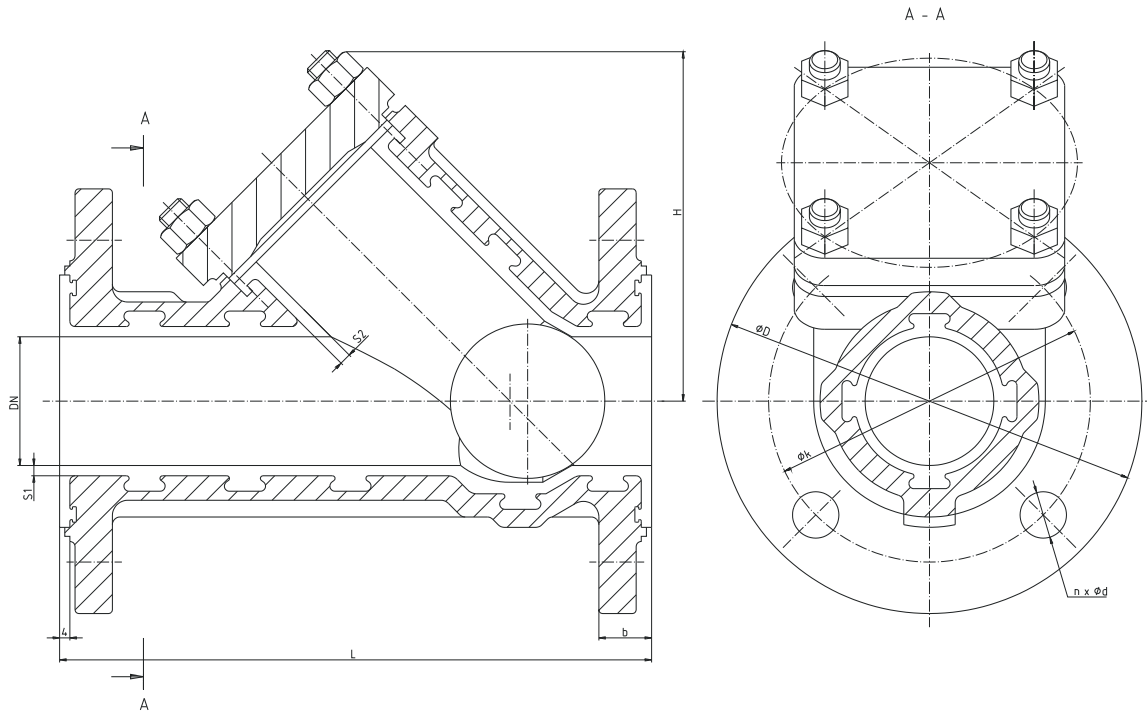

DN / DIN	L	b	ØD	Øk	nxØd	S1	S2	H	
025	mm	160	17	115	85	4x14	3	3,5	90
	inch	6,3	0,67	4,53	3,35	4x0,55	0,11	0,13	3,54
040	mm	200	21,5	150	110	4x18	4	4	126
	inch	7,87	0,85	5,9	4,33	4x0,71	0,16	0,16	4,96
050	mm	230	20,5	165	125	4x18	4	4,5	136
	inch	9,06	0,81	6,5	4,92	4x0,71	0,16	0,17	5,35
080	mm	310	24,5	200	160	8x18	5	5	208
	inch	12,2	0,96	7,87	6,3	8x0,71	0,2	0,2	8,19

Face-to-Face Dimension: DIN EN 558 (Basic series 1)
 Flange Connection: DIN EN 1092 - 2 (PN 16)
 Tightness test: DIN EN 12266-1 (leak rate B)

Dimensions ARL

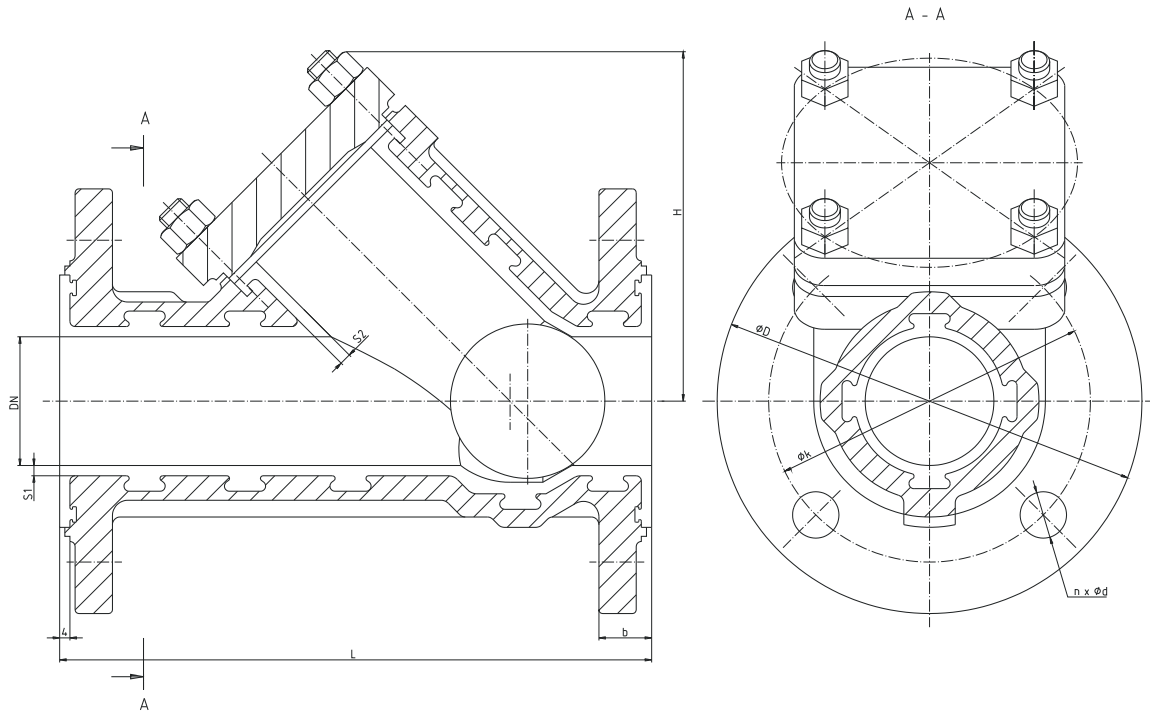

DN / ANSI		L	b	ØD	Øk	nxØd	S1	S2	H
1"	mm	160	17	107,9	79,2	4x16	3	3,5	90
	inch	6,3	0,67	4,25	3,35	4x0,63	0,11	0,13	3,54
1½"	mm	200	21,5	127	98,6	4x16	4	4	126
	inch	7,87	0,85	5	3,88	4x0,63	0,16	0,16	4,96
2"	mm	230	20,5	152	120,7	4x18	4	4,5	136
	inch	9,06	0,81	6	4,75	4x0,71	0,16	0,17	5,35
3"	mm	310	24,5	190,5	152,4	4x19	5	5	208
	inch	12,2	0,96	7,5	6,3	4x0,75	0,2	0,2	8,19

Face-to-Face Dimension: DIN EN 558 (Basic series 1)
 Flange Connection: ANSI B 16.5 - 150 lbs
 Tightness test: DIN EN 12266-1 (leak rate B)

Spare Parts (item n°) - ARL

DIN	ANSI	ball	flat gasket PTFE
025	1"	0001451	0015668
040	1½"	0001452	0015667
050	2"	0001453	0014088
080	3"	0001454	0019149

ASSEMBLY INSTRUCTIONS ARL

The general installation and maintenance instructions must be observed.

1. Screw stud bolts **(040)** into body **(010)**.
2. Insert ball **(030)** into body **(010)**.
3. Place the gasket **(060)** in the provided alignment.
4. Assemble the bonnet **(020)** and screw hexagon nuts **(050)** on to stud bolts **(040)** by nuts **(050)** on to stud bolts **(040)** by criss-cross method acc. to recommended torques.

DISASSEMBLY INSTRUCTIONS ARL

For all jobs which are to be carried out on an installed valve, the works safety requirements and the general installation and maintenance instructions for fluor-carbon resin lined atomac valves must be observed.

1. Prior to disassembling, the valve must be drained of all line media, acc. to the above mentioned instructions.
2. To get the ball **(030)**, first remove hexagon nuts **(050)**. Then bonnet **(020)** and the gasket **(060)** can be removed.

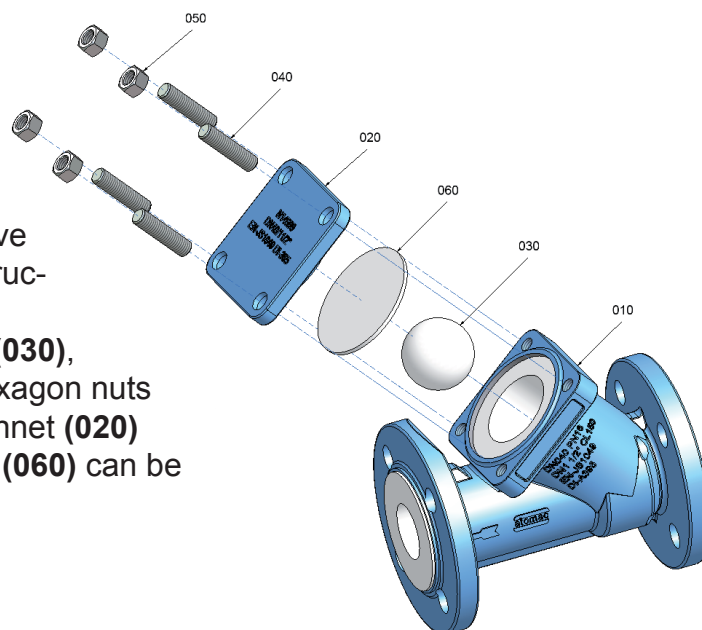

Technical Manual

ARL - recommended tightening torques*

DN	tie rods (040/050)		connection flange	
	Nm	in.lbs	Nm	in.lbs
025	16	142	25	221
1"	17,5	155	15	133
040	--	--	50	442
1½"	--	--	50	442
050	58	513	65	575
2"	62	549	60	531
080	55	487	55	487
3"	59,5	527	100	885

* max. value

ARL - K_v Data and C_v Data (DIN EN 60534-2-3)

DIN	ANSI	K _v m³/h	C _v gal/min
025	1"	18,8	21,8
040	1 ½"	42,2	49,0
050	2"	78,3	91,0
080	3"	183,0	212,7